

## Model: NUP2210ECP

Basic size of  
 mm

d:	50
D:	90
B:	23

The basic rated load is  
 kN

trends C:	90
static state Co:	88
Fatigue load limit Pu:	11.4

Rated rotation speed is  
 r/min

Refer to the speed:	8500
limit speed:	9000
Specification standard holder:	0.59

model

Standard holder:	*NUP2210ECP
Other holder 1):	J,ML

Dimensions are  
 mm

d:	50
d <sub>1</sub> ~ :	64
D1 ~ :	78
F,E:	59.5
r <sub>1,2</sub> the min:	1.1
r <sub>3,4</sub> the min:	1.1
s <sup>1)</sup> :	-

Shoulder gear and chamfer size  
 mm

d <sub>a</sub> the min:	57
d <sub>a</sub> the max:	-
d <sub>b</sub> ,Da the min:	66
Da the max:	83

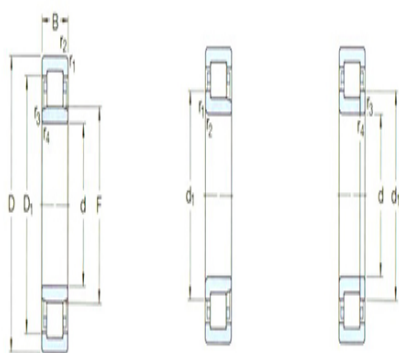

NU

NU

NUP

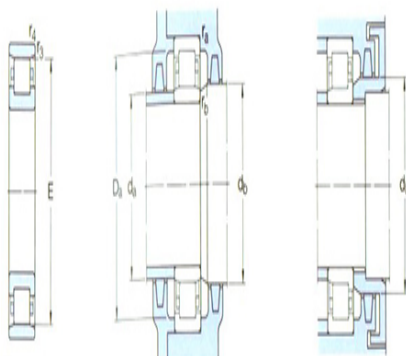

N

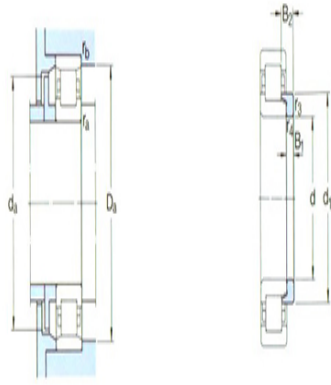

角鋼

$r_a$  the max: 1

$r_b$  the max: 1

Calculation coefficient

kr: 0.2

Corner circle

model: -

quality: -

Size B1: -

Size B2: -