

Model: NJ310ECP

Basic size of
mm

d:	50
D:	110
B:	27

The basic rated load is
kN

trends C:	127
static state Co:	112
Fatigue load limit Pu:	15

Rated rotation speed is
r/min

Refer to the speed:	6700
limit speed:	8000
Specification standard holder:	1.15

model

Standard holder:	*NJ310ECP
Other holder 1):	J,M,ML

Dimensions are
mm

d:	50
d ₁ ~ :	71.2
D1 ~ :	92.1
F,E:	65
r _{1,2} the min:	2
r _{3,4} the min:	2
s ¹⁾ :	1.9

Shoulder gear and chamfer size
mm

d _a the min:	61
d _a the max:	63
d _b ,D _a the min:	73
D _a the max:	99

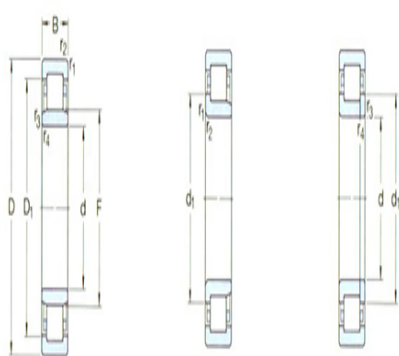

NU

NU

NUP

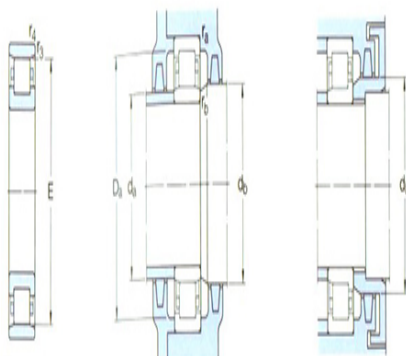

N

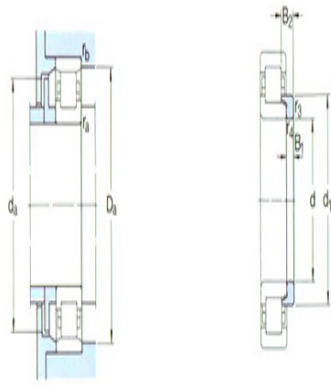

图例

r_a the max: 2

r_b the max: 2

Calculation coefficient

kr: 0.15

Corner circle

model: HJ310EC

quality: 0.14

Size B1: 8

Size B2: 13