



Model: NUP2311ECP

Basic size of
 mm

d:	55
D:	120
B:	43

The basic rated load is
 kN

trends C:	232
static state Co:	232
Fatigue load limit Pu:	30.5

Rated rotation speed is
 r/min

Refer to the speed:	6000
limit speed:	7000
Specification standard holder:	2.35

model

Standard holder:	*NUP2311ECP
Other holder 1):	ML

Dimensions are
 mm

d:	55
d ₁ ~ :	77.5
D1 ~ :	101
F,E:	70.5
r _{1,2} the min:	2
r _{3,4} the min:	2
s ¹⁾ :	-

Shoulder gear and chamfer size
 mm

d _a the min:	66
d _a the max:	-
d _b ,D _a the min:	80
D _a the max:	109

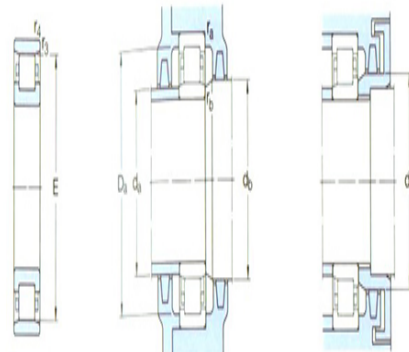
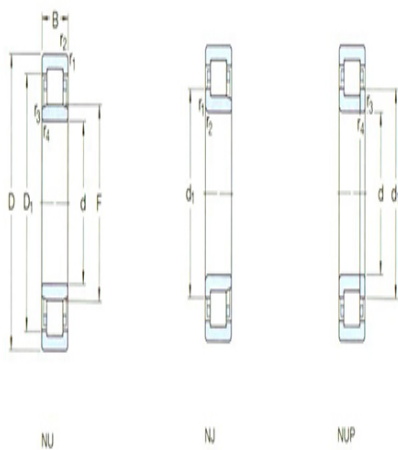

N

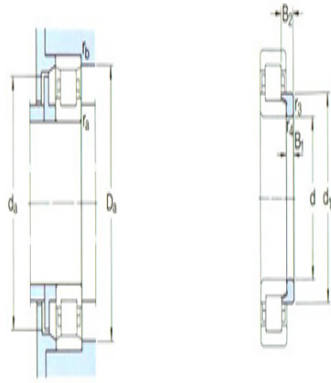

角鋼

r_a the max: 2

r_b the max: 2

Calculation coefficient

kr: 0.25

Corner circle

model: -

quality:

Size B1:

Size B2: