



Model: NUP2215ECP

Basic size of
 mm

d:	75
D:	130
B:	31

The basic rated load is
 kN

trends C:	186
static state Co:	208
Fatigue load limit Pu:	27

Rated rotation speed is
 r/min

Refer to the speed:	5600
limit speed:	6000
Specification standard holder:	1.65

model

Standard holder:	*NUP2215ECP
Other holder 1):	J,ML

Dimensions are
 mm

d:	75
d ₁ ~ :	94.3
D1 ~ :	114
F,E:	88.5
r _{1,2} the min:	1.5
r _{3,4} the min:	1.5
s ¹⁾ :	-

Shoulder gear and chamfer size
 mm

d _a the min:	84
d _a the max:	-
d _b ,D _a the min:	97
D _a the max:	121

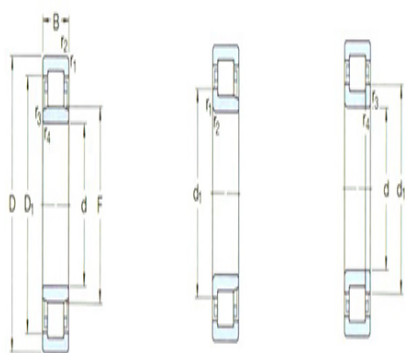

NU

N

NUP

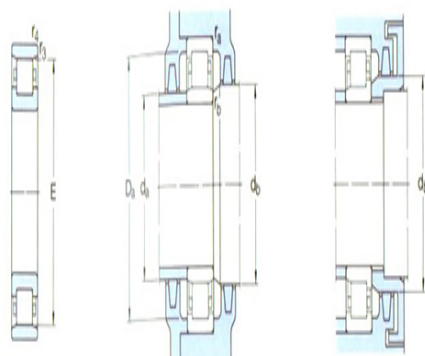

N



11

r_a the max: 1.5

r_b the max: 1.5

Calculation coefficient

kr: 0.2

Corner circle

model: -

quality: -

Size B1: -

Size B2: -