

Model: NU315ECP

Basic size of
mm

d:	75
D:	160
B:	37

The basic rated load is
kN

trends C:	280
static state Co:	265
Fatigue load limit Pu:	33.5

Rated rotation speed is
r/min

Refer to the speed:	4500
limit speed:	5300
Specification standard holder:	3.3

model

Standard holder:	*NU315ECP
Other holder 1):	J,M,ML

Dimensions are
mm

d:	75
d ₁ ~ :	104
D1 ~ :	136
F,E:	95
r _{1,2} the min:	2.1
r _{3,4} the min:	2.1
s ¹⁾ :	1.8

Shoulder gear and chamfer size
mm

d _a the min:	87
d _a the max:	92
d _b ,D _a the min:	97
D _a the max:	148

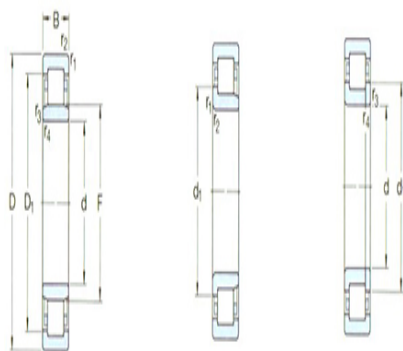

NU

NU

NUP

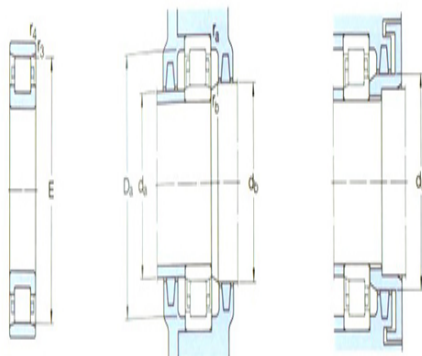

N



9/11

r_a the max:	2
r_b the max:	2

Calculation coefficient

kr:	0.15
-----	------

Corner circle

model:	HJ315EC
quality:	0.39
Size B1:	11
Size B2:	16.5