



Model: NUP315ECP

Basic size of
mm

d:	75
D:	160
B:	37

The basic rated load is
kN

trends C:	280
static state Co:	265
Fatigue load limit Pu:	33.5

Rated rotation speed is
r/min

Refer to the speed:	4500
limit speed:	5300
Specification standard holder:	3.45

model

Standard holder:	*NUP315ECP
Other holder 1):	M,ML

Dimensions are
mm

d:	75
d ₁ ~ :	104
D1 ~ :	136
F,E:	95
r _{1,2} the min:	2.1
r _{3,4} the min:	2.1
s ¹⁾ :	-

Shoulder gear and chamfer size
mm

d _a the min:	87
d _a the max:	-
d _b ,D _a the min:	107
D _a the max:	148

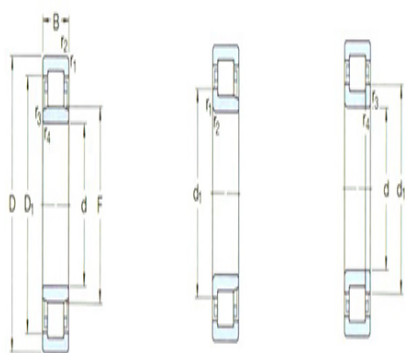

NU

N

NUP

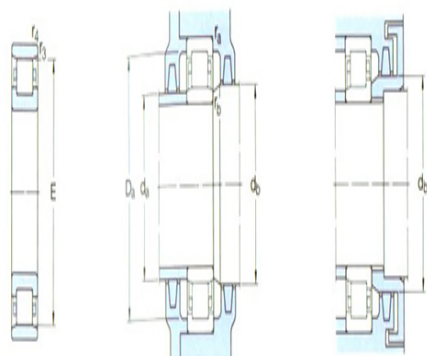

N



1/1

r_a the max: 2

r_b the max: 2

Calculation coefficient

kr: 0.15

Corner circle

model: -

quality: -

Size B1: -

Size B2: -