

Model: NU1020ML

Basic size of
mm

d:	100
D:	150
B:	24

The basic rated load is
kN

trends C:	85.8
static state Co:	114
Fatigue load limit Pu:	13.7

Rated rotation speed is
r/min

Refer to the speed:	5000
limit speed:	7500
Specification standard holder:	1.45

model

Standard holder:	NU1020M L
Other holder 1):	M

Dimensions are
mm

d:	100
d ₁ ~ :	-
D1 ~ :	132
F,E:	113
r _{1,2} the min:	1.5
r _{3,4} the min:	1.1
s ¹⁾ :	3.5

Shoulder gear and chamfer size
mm

d _a the min:	106
d _a the max:	111
d _b ,D _a the min:	116
D _a the max:	143

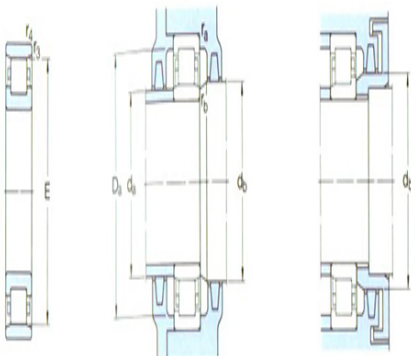
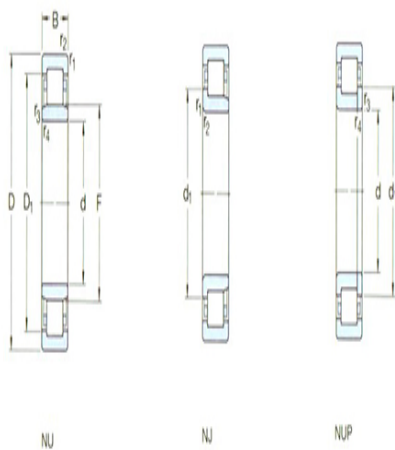

N

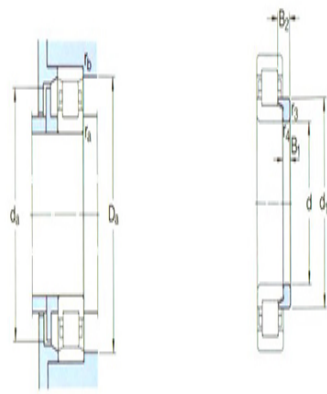

r_a the max:	1.5
r_b the max:	1

Calculation coefficient

kr:	0.1
-----	-----

Corner circle

model:	-
quality:	-
Size B1:	-
Size B2:	-