



Model: NUP320ECJ

Basic size of
 mm

d:	100
D:	215
B:	47

The basic rated load is
 kN

trends C:	450
static state Co:	440
Fatigue load limit Pu:	51

Rated rotation speed is
 r/min

Refer to the speed:	3200
limit speed:	3800
Specification standard holder:	7.8

model

Standard holder:	*NUP320EC J
Other holder 1):	ML

Dimensions are
 mm

d:	100
d ₁ ~ :	139
D1 ~ :	182
F,E:	127.5
r _{1,2} the min:	3
r _{3,4} the min:	3
s ¹⁾ :	-

Shoulder gear and chamfer size
 mm

d _a the min:	114
d _a the max:	-
d _b ,D _a the min:	142
D _a the max:	201

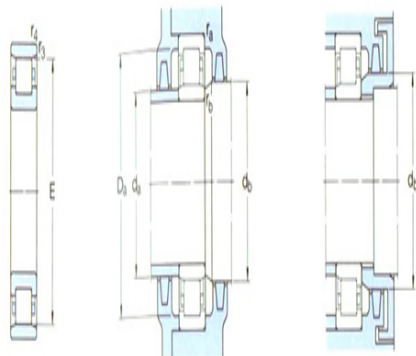
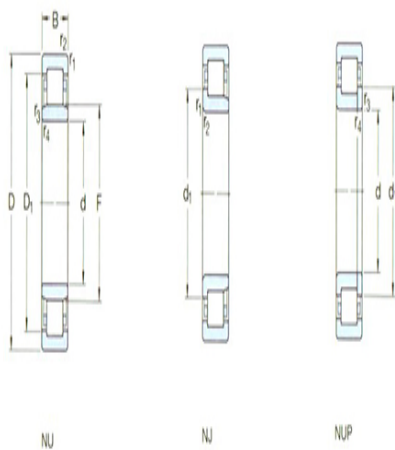

N

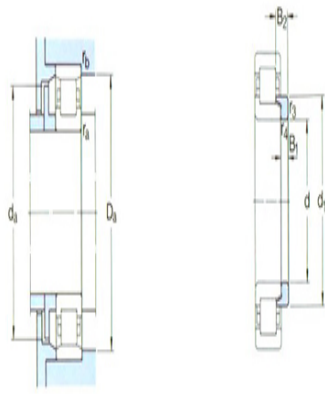

111

r_a the max: 2.5

r_b the max: 2.5

Calculation coefficient

kr: 0.15

Corner circle

model: -

quality: -

Size B1: -

Size B2: -