



Model: NU420M

Basic size of
 mm

d:	100
D:	250
B:	58

The basic rated load is
 kN

trends C:	429
static state Co:	475
Fatigue load limit Pu:	53

Rated rotation speed is
 r/min

Refer to the speed:	3000
limit speed:	3600
Specification standard holder:	14

model

Standard holder:	NU420 M
Other holder 1):	-

Dimensions are
 mm

d:	100
d ₁ ~ :	-
D1 ~ :	195
F,E:	139
r _{1,2} the min:	4
r _{3,4} the min:	4
s ¹⁾ :	4.9

Shoulder gear and chamfer size
 mm

d _a the min:	120
d _a the max:	135
d _b ,D _a the min:	142
D _a the max:	230

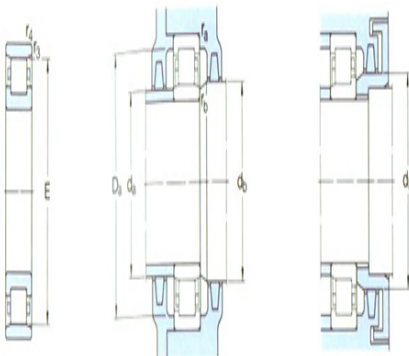
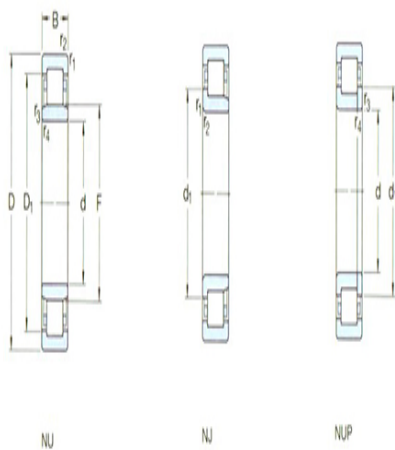

N

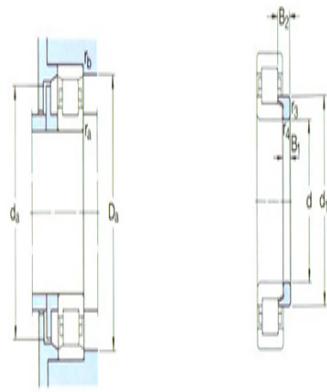

111

r_a the max: 3

r_b the max: 3

Calculation coefficient

kr: 0.15

Corner circle

model: -

quality: -

Size B1: -

Size B2: -