



Model: NUP221ECP

Basic size of
mm

d:	105
D:	190
B:	36

The basic rated load is
kN

trends C:	300
static state Co:	315
Fatigue load limit Pu:	36.5

Rated rotation speed is
r/min

Refer to the speed:	3800
limit speed:	4300
Specification standard holder:	4.2

model

Standard holder:	*NUP221ECP
Other holder 1):	ML

Dimensions are
mm

d:	105
d ₁ ~ :	134
D1 ~ :	164
F,E:	125
r _{1,2} the min:	2.1
r _{3,4} the min:	2.1
s ¹⁾ :	-

Shoulder gear and chamfer size
mm

d _a the min:	117
d _a the max:	-
d _b ,D _a the min:	137
D _a the max:	178

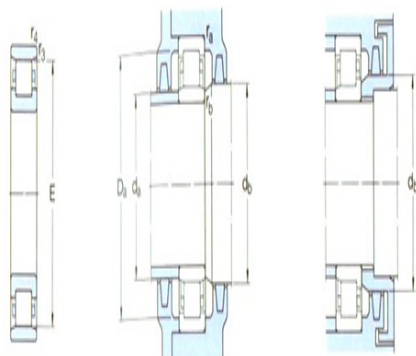
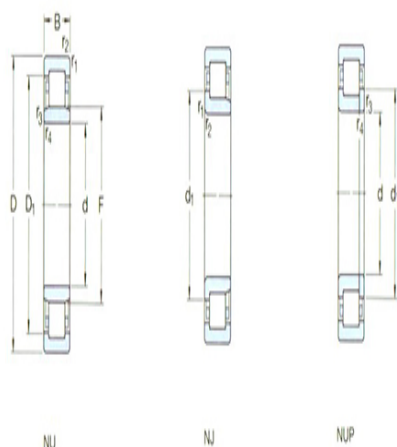

N

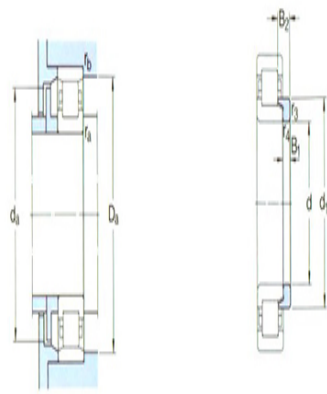

r_a the max:	2
r_b the max:	2

Calculation coefficient

kr:	0.15
-----	------

Corner circle

model:	-
quality:	-
Size B1:	-
Size B2:	-