

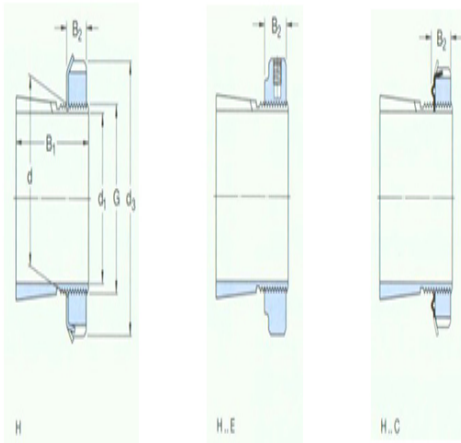

Model: HMV10E

size

d ₁ :	45
d:	50
d ₃ :	70
B ₁ :	42
B ₂ :	14
G:	M50×1.5
quality:	0.3



model

Tset ings with locking nuts and locking device:	H310E
locknut:	KMFE10
locking apparatus:	-
Applicable hydraulic pressure nuts:	HMV10E