

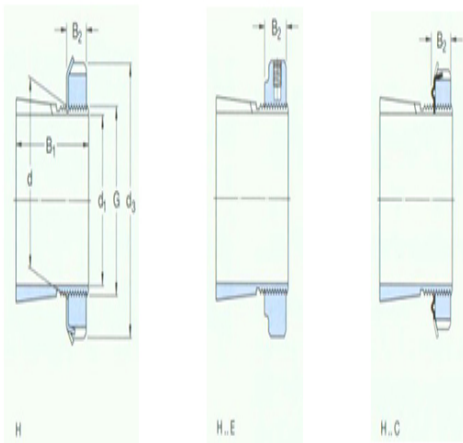

**Model: HMV11E**

size

d <sub>1</sub> :	50
d:	55
d <sub>3</sub> :	75
B <sub>1</sub> :	37
B <sub>2</sub> :	12.5
G:	M55×2
quality:	0.28



model

Tset ings with locking nuts and locking device:	H211
locknut:	KM11
locking apparatus:	MB11
Applicable hydraulic pressure nuts:	HMV11 E