

HGW-CB / HGW-HB

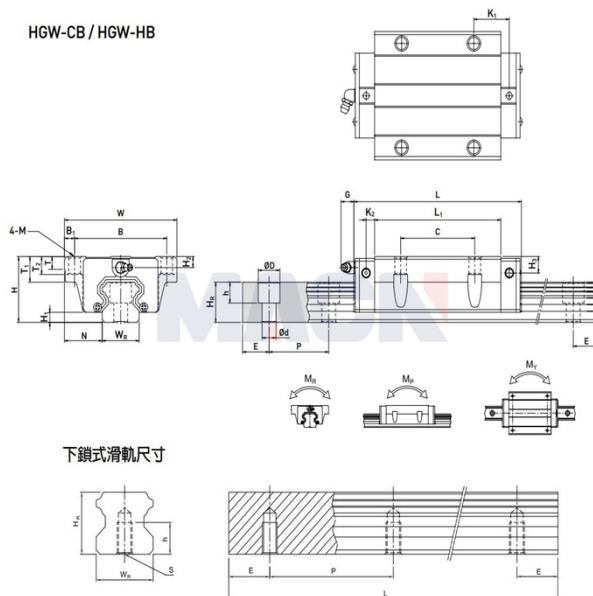

Model: HGW15CB

Param

Guide rail model:	HGW15CB
Slider special processing:	无
Number type of slider:	单个
Guide rail fixation mode:	上锁式
Guide rail length L:	340
L computational formula:	$L=(n-1) \times P+2 \times E$ n=1,2,3....
Special processing of guide rail:	无
Pre-pressure grade:	无预压(ZO)
accuracy class:	普通(C)
dustproof equipped with grade:	标准防尘配备
Dust equipped with:	标准(刮油片+防尘片)
Special selection:	无
RC reinforced bolt cover:	无
Component size:	
H:	24
H1:	4.3
N:	16
Slider size:	
W:	47
B:	38
B1:	4.5
C:	30
L:	61.4
L1:	39.4

K1:	8
K2:	4.85
G:	5.3
M:	Φ4.5
T:	6
T1:	8.9
T2:	6.95
H2:	3.95
H3:	3.7
Guide track size:	
WR:	15
HR:	15
D:	7.5
h:	5.3
d:	4.5
P:	60
Standard end distance E:	20
Actual end distance:	20
Number of bolt holes n:	6
Guide rail fixed bolt:	M4x16
Rated dynamic load C:	11.38
Rated static load Co:	16.97
Rated static moment MR:	0.12
Rated static moment, MP:	0.10
Rated static moment, MY:	0.10
Slider weight:	0.17
Guide rail weight:	1.45