

HGW-CB / HGW-HB

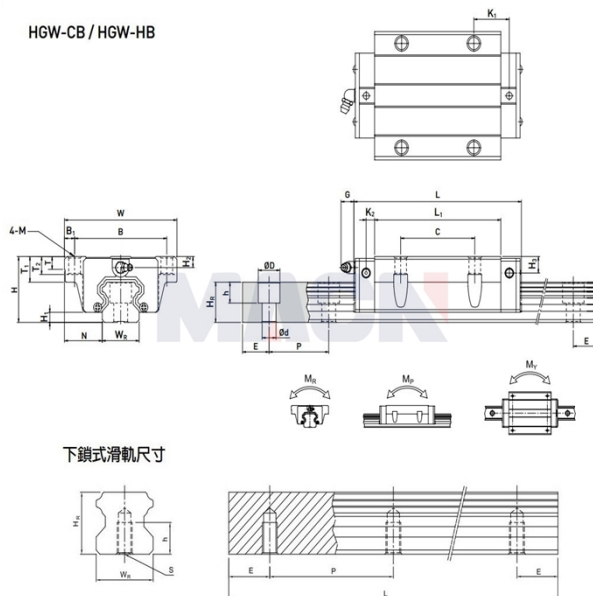

Model: HGW55CB

Param

Guide rail model:	HGW55CB
Slider special processing:	无
Number type of slider:	单个
Guide rail fixation mode:	上锁式
Guide rail length L:	900
L computational formula:	$L=(n-1) \times P+2 \times E$ n=1,2,3....
Special processing of guide rail:	无
Pre-pressure grade:	无预压(ZO)
accuracy class:	普通(C)
dustproof equipped with grade:	标准防尘配备
Dust equipped with:	标准(刮油片+防尘片)
Special selection:	无
RC reinforced bolt cover:	无
Component size:	
H:	70
H1:	13
N:	43.5
Slider size:	
W:	140
B:	116
B1:	12
C:	95
L:	166.7
L1:	117.7

K1:	17.35
K2:	11
G:	12.9
M:	Φ14
T:	17.5
T1:	26.5
T2:	17
H2:	12
H3:	19
Guide track size:	
WR:	53
HR:	44
D:	23
h:	20
d:	16
P:	120
Standard end distance E:	30
Actual end distance:	30
Number of bolt holes n:	8
Guide rail fixed bolt:	M14x45
Rated dynamic load C:	114.44
Rated static load Co:	148.33
Rated static moment MR:	3.69
Rated static moment, MP:	2.64
Rated static moment, MY:	2.64
Slider weight:	4.52
Guide rail weight:	15.08