

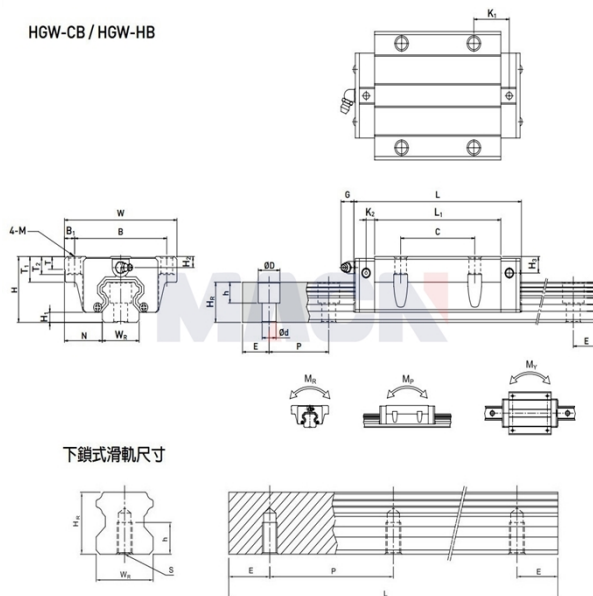

HGW-CB / HGW-HB



Model: HGW65CB

Param

Guide rail model:	HGW65CB
Slider special processing:	无
Number type of slider:	单个
Guide rail fixation mode:	上锁式
Guide rail length L:	1270
L computational formula:	$L=(n-1) \times P+2 \times E$ n=1,2,3....
Special processing of guide rail:	无
Pre-pressure grade:	无预压(ZO)
accuracy class:	普通(C)
dustproof equipped with grade:	标准防尘配备
Dust equipped with:	标准(刮油片+防尘片)
Special selection:	无
RC reinforced bolt cover:	无
Component size:	
H:	90
H1:	15
N:	53.5
Slider size:	
W:	170
B:	142
B1:	14
C:	110
L:	200.2
L1:	144.2

K1:	23.1
K2:	14
G:	12.9
M:	Φ16
T:	25
T1:	37.5
T2:	23
H2:	15
H3:	15
Guide track size:	
WR:	63
HR:	53
D:	26
h:	22
d:	18
P:	150
Standard end distance E:	35
Actual end distance:	35
Number of bolt holes n:	9
Guide rail fixed bolt:	M16x50
Rated dynamic load C:	163.63
Rated static load Co:	215.33
Rated static moment MR:	6.65
Rated static moment, MP:	4.27
Rated static moment, MY:	4.27
Slider weight:	9.17
Guide rail weight:	21.18