

HGL-CA / HGL-HA

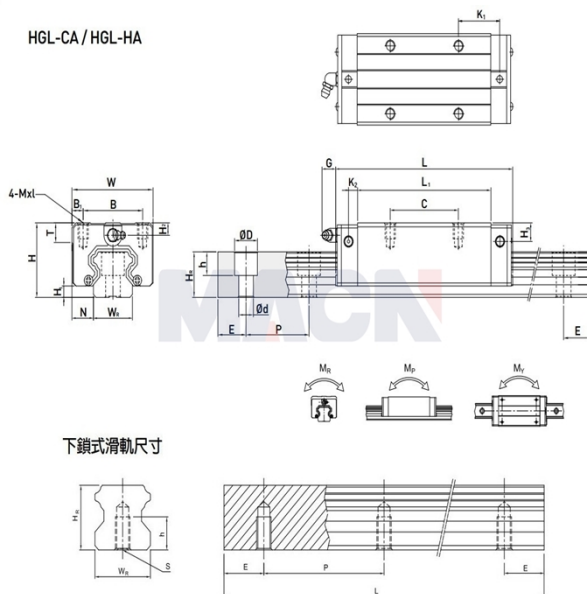

Model: HGL45CA

Param

Guide rail model:	HGL45CA
Slider special processing:	无
Number type of slider:	单个
Guide rail fixation mode:	上锁式
Guide rail length L:	780
L computational formula:	$L=(n-1) \times P+2 \times E$ n=1,2,3....
Special processing of guide rail:	无
Pre-pressure grade:	无预压(ZO)
accuracy class:	普通(C)
dustproof equipped with grade:	标准防尘配备
Dust equipped with:	标准(刮油片+防尘片)
Special selection:	无
RC reinforced bolt cover:	无
Component size:	
H:	60
H1:	9.5
N:	20.5
Slider size:	
W:	86
B:	60
B1:	13
C:	60
L:	139.4
L1:	97

K1:	23
K2:	10
G:	12.9
MxL:	M10x17
T:	16
H2:	8.5
H3:	20.5
Guide track size:	
WR:	45
HR:	38
D:	20
h:	17
d:	14
P:	105
Standard end distance E:	22.5
Actual end distance:	22.5
Number of bolt holes n:	8
Guide rail fixed bolt:	M12x35
Rated dynamic load C:	77.57
Rated static load Co:	102.71
Rated static moment MR:	1.98
Rated static moment, MP:	1.55
Rated static moment, MY:	1.55
Slider weight:	2.08
Guide rail weight:	10.41