

EGW-SA / EGW-CA

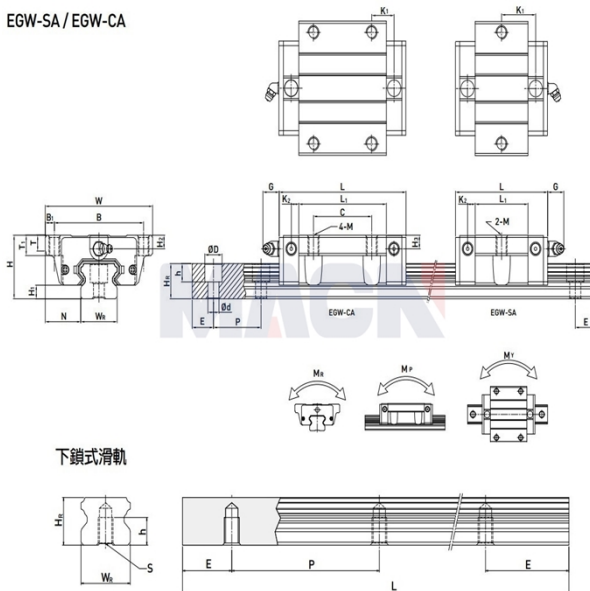

下鎖式滑軌

Model: EGW15SA

Param

| | |
|-----------------------------------|--------------------------------------------------|
| Guide rail model: | EGW15SA |
| Slider special processing: | 无 |
| Number type of slider: | 单个 |
| Guide rail fixation mode: | 上锁式 |
| Guide rail length L: | 340 |
| L computational formula: | $L=(n-1) \times P+2 \times E$ $n=1,2,3 \dots$ |
| Special processing of guide rail: | 无 |
| Pre-pressure grade: | 无预压(ZO) |
| accuracy class: | 普通(C) |
| dustproof equipped with grade: | 标准防尘配备 |
| Dust equipped with: | 标准(刮油片+防尘片) |
| Special selection: | 无 |
| RC reinforced bolt cover: | 无 |
| Component size: | |
| H: | 24 |
| H1: | 4.5 |
| N: | 18.5 |
| Slider size: | |
| W: | 52 |
| B: | 41 |
| B1: | 5.5 |
| C: | - |
| L: | 40.1 |
| L1: | 23.1 |

| | |
|-----------------------------|-------|
| K1: | 14.8 |
| K2: | 3.5 |
| G: | 5.7 |
| M: | M5 |
| T: | 5 |
| T1: | 7 |
| H2: | 5.5 |
| H3: | 6 |
| Guide track size: | |
| WR: | 15 |
| HR: | 12.5 |
| D: | 6 |
| h: | 4.5 |
| d: | 3.5 |
| P: | 60 |
| Standard end distance E: | 20 |
| Actual end distance: | 20 |
| Number of bolt holes n: | 6 |
| Guide rail fixed bolt: | M3x16 |
| Rated dynamic load C: | 5.35 |
| Rated static load Co: | 9.40 |
| Rated static moment MR: | 0.08 |
| Rated static moment, MP: | 0.04 |
| Rated static moment, MY: | 0.04 |
| Slider weight: | 0.12 |
| Guide rail weight: | 1.25 |