

EGW-SA / EGW-CA

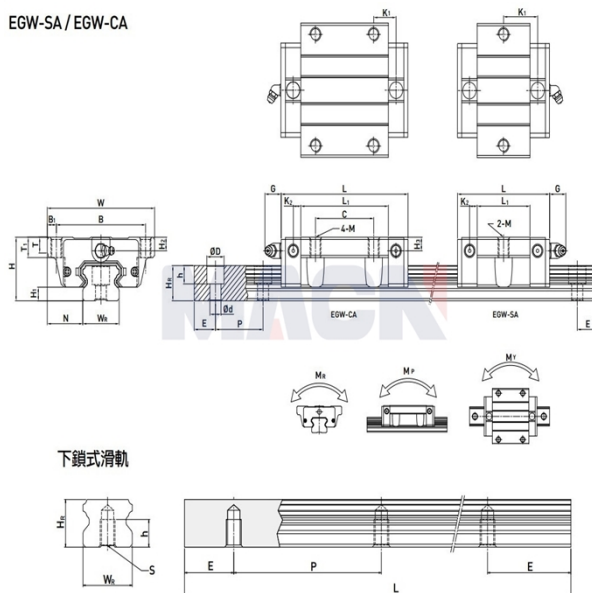

Model: EGW35SA

Param

Guide rail model:	EGW35SA
Slider special processing:	无
Number type of slider:	单个
Guide rail fixation mode:	上锁式
Guide rail length L:	440
L computational formula:	$L=(n-1) \times P+2 \times E$ n=1,2,3....
Special processing of guide rail:	无
Pre-pressure grade:	无预压(ZO)
accuracy class:	普通(C)
dustproof equipped with grade:	标准防尘配备
Dust equipped with:	标准(刮油片+防尘片)
Special selection:	无
RC reinforced bolt cover:	无
Component size:	
H:	48
H1:	11
N:	33
Slider size:	
W:	100
B:	82
B1:	9
C:	-
L:	75
L1:	45

K1:	28.5
K2:	7
G:	12
M:	M10
T:	10
T1:	13
H2:	8.5
H3:	8.5
Guide track size:	
WR:	34
HR:	27.5
D:	14
h:	12
d:	9
P:	80
Standard end distance E:	20
Actual end distance:	20
Number of bolt holes n:	6
Guide rail fixed bolt:	M8x25
Rated dynamic load C:	22.66
Rated static load Co:	37.38
Rated static moment MR:	0.56
Rated static moment, MP:	0.31
Rated static moment, MY:	0.31
Slider weight:	0.84
Guide rail weight:	6.14