



**Model: MGW9H**

**Param**

Guide rail model:	MGW9H
Slider special processing:	无
Number type of slider:	单个
Guide rail length L:	200
L computational formula:	$L=(n-1) \times P+2 \times E$ n=1,2,3....
Special processing of guide rail:	无
Pre-pressure grade:	普通间隙(ZF)
accuracy class:	普通(C)
Guide track material:	普通钢
dustproof equipped with grade:	标准防尘配备
Dust equipped with:	标准(刮油片)
Component size:	
H:	12
H1:	2.9
N:	6
Slider size:	
W:	30
B:	23
B1:	3.5
C:	24
L1:	38.5
L:	50.7
G:	-
Gn:	φ 1.2
MxL:	M3x3
H2:	2.4
Guide track size:	

**MGW-C / MGW-H**

MGW7, MGW9, MGW12

MGW15

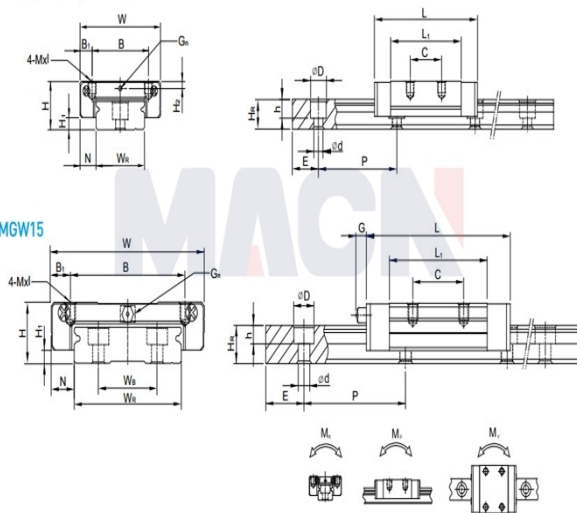

WR:	18
WB:	-
HR:	7
D:	6
h:	4.5
d:	3.5
P:	30
Standard end distance E:	10
Actual end distance:	10
Number of bolt holes n:	7
Guide rail fixed bolt:	M3x8
Rated dynamic load C:	3.43
Rated static load Co:	5.89
Rated static moment MR:	54.54
Rated static moment, MP:	34.00
Rated static moment, MY:	34.00
Slider weight:	0.057
Guide rail weight:	0.91