

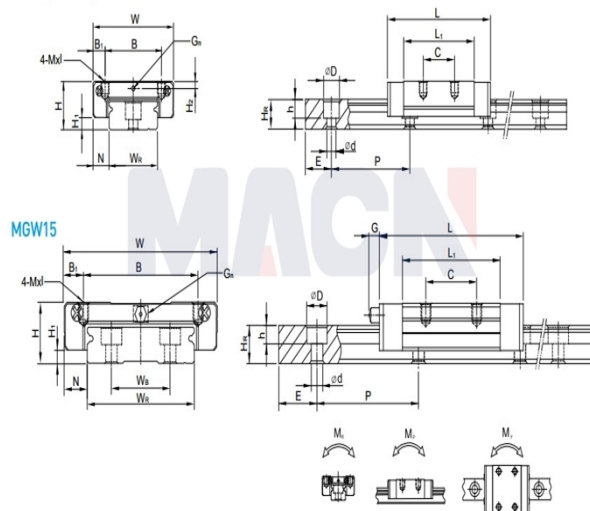

**MGW-C / MGW-H**

MGW7, MGW9, MGW12



**Model: MGW7C**

**Param**

Guide rail model:	MGW7C
Slider special processing:	无
Number type of slider:	单个
Guide rail length L:	200
L computational formula:	$L=(n-1) \times P+2 \times E$ n=1,2,3....
Special processing of guide rail:	无
Pre-pressure grade:	普通间隙(ZF)
accuracy class:	普通(C)
Guide track material:	普通钢
dustproof equipped with grade:	标准防尘配备
Dust equipped with:	标准(刮油片)
Component size:	
H:	9
H1:	1.9
N:	5.5
Slider size:	
W:	25
B:	19
B1:	3
C:	10
L1:	21
L:	31.2
G:	-
Gn:	φ 1.2
MxL:	M3x3
H2:	1.85
Guide track size:	

WR:	14
WB:	-
HR:	5.2
D:	6
h:	3.2
d:	3.5
P:	30
Standard end distance E:	10
Actual end distance:	10
Number of bolt holes n:	7
Guide rail fixed bolt:	M3x6
Rated dynamic load C:	1.37
Rated static load Co:	2.06
Rated static moment MR:	15.70
Rated static moment, MP:	7.14
Rated static moment, MY:	7.14
Slider weight:	0.020
Guide rail weight:	0.51