

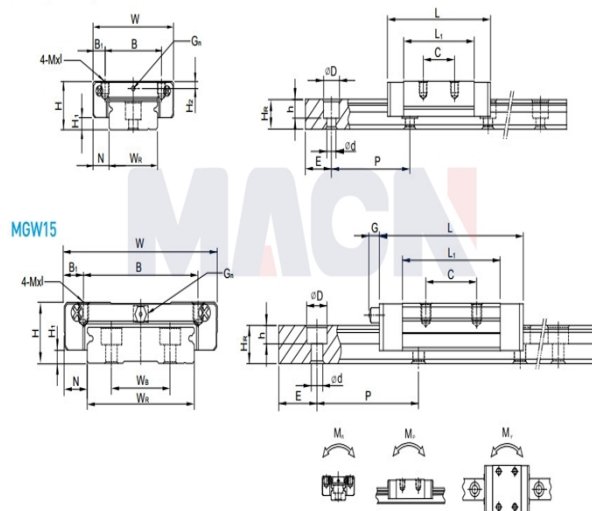

MGW-C / MGW-H

MGW7, MGW9, MGW12



Model: MGW15C

Param

Guide rail model:	MGW15C
Slider special processing:	无
Number type of slider:	单个
Guide rail length L:	270
L computational formula:	$L=(n-1) \times P+2 \times E$ n=1,2,3....
Special processing of guide rail:	无
Pre-pressure grade:	普通间隙(ZF)
accuracy class:	普通(C)
Guide track material:	普通钢
dustproof equipped with grade:	标准防尘配备
Dust equipped with:	标准(刮油片)
RC reinforced bolt cover:	无
Component size:	
H:	16
H1:	3.4
N:	9
Slider size:	
W:	60
B:	45
B1:	7.5
C:	20
L1:	38
L:	54.8
G:	5.2
Gn:	M3
MxL:	M4x4.2

H2:	3.2
Guide track size:	
WR:	42
WB:	23
HR:	9.5
D:	8
h:	4.5
d:	4.5
P:	40
Standard end distance E:	15
Actual end distance:	15
Number of bolt holes n:	7
Guide rail fixed bolt:	M4x10
Rated dynamic load C:	6.77
Rated static load Co:	9.22
Rated static moment MR:	199.34
Rated static moment, MP:	56.66
Rated static moment, MY:	56.66
Slider weight:	0.143
Guide rail weight:	2.86