

QHW-CC / QHW-HC

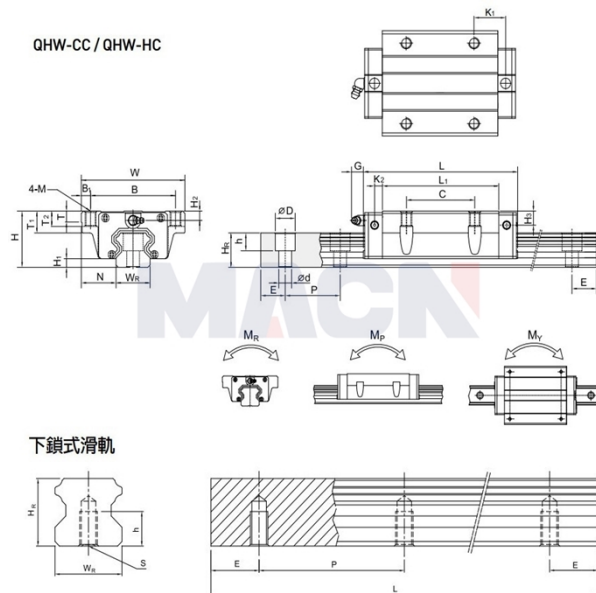

下鎖式滑軌

Model: QHW30CC

Param

Guide rail model:	QHW30CC
Slider special processing:	无
Number type of slider:	单个
Guide rail fixation mode:	上锁式
Guide rail length L:	440
L computational formula:	$L=(n-1) \times P+2 \times E$ $n=1,2,3, \dots$
Special processing of guide rail:	无
Pre-pressure grade:	无预压(ZO)
accuracy class:	普通(C)
dustproof equipped with grade:	标准防尘配备
Dust equipped with:	标准(刮油片+防尘片)
Special selection:	无
RC reinforced bolt cover:	无
Component size:	
H:	42
H1:	6
N:	31
Slider size:	
W:	90
B:	72
B1:	9
C:	52
L:	97.4
L1:	70

K1:	13.5
K2:	6.25
G:	12
M:	M10
T:	8.5
T1:	16
T2:	10
H2:	6.5
H3:	6
Guide track size:	
WR:	28
HR:	26
D:	14
h:	12
d:	9
P:	80
Standard end distance E:	20
Actual end distance:	20
Number of bolt holes n:	6
Guide rail fixed bolt:	M8x25
Rated dynamic load C:	46.49
Rated static load Co:	48.17
Rated static moment MR:	0.60
Rated static moment, MP:	0.50
Rated static moment, MY:	0.50
Slider weight:	1.09
Guide rail weight:	4.47