

QHW-CC / QHW-HC

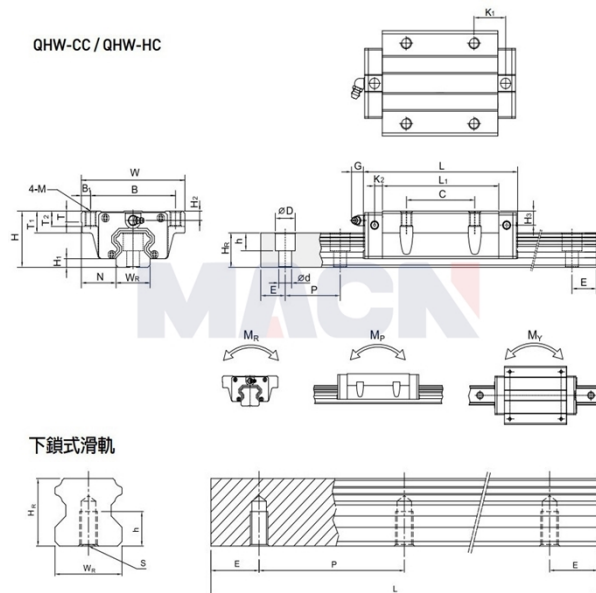

下鎖式滑軌

## Model: QHW45CC

### Param

Guide rail model:	QHW45CC
Slider special processing:	无
Number type of slider:	单个
Guide rail fixation mode:	上锁式
Guide rail length L:	780
L computational formula:	$L=(n-1) \times P+2 \times E$ $n=1,2,3, \dots$
Special processing of guide rail:	无
Pre-pressure grade:	无预压(ZO)
accuracy class:	普通(C)
dustproof equipped with grade:	标准防尘配备
Dust equipped with:	标准(刮油片+防尘片)
Special selection:	无
RC reinforced bolt cover:	无
Component size:	
H:	60
H1:	9.2
N:	37.5
Slider size:	
W:	120
B:	100
B1:	10
C:	80
L:	139.4
L1:	97

K1:	13
K2:	10
G:	12.9
M:	M12
T:	15.1
T1:	22
T2:	15
H2:	8.5
H3:	10
Guide track size:	
WR:	45
HR:	38
D:	20
h:	17
d:	14
P:	105
Standard end distance E:	22.5
Actual end distance:	22.5
Number of bolt holes n:	8
Guide rail fixed bolt:	M12x35
Rated dynamic load C:	89.21
Rated static load Co:	94.81
Rated static moment MR:	1.83
Rated static moment, MP:	1.38
Rated static moment, MY:	1.38
Slider weight:	2.79
Guide rail weight:	10.41