

QHW-CB / QHW-HB

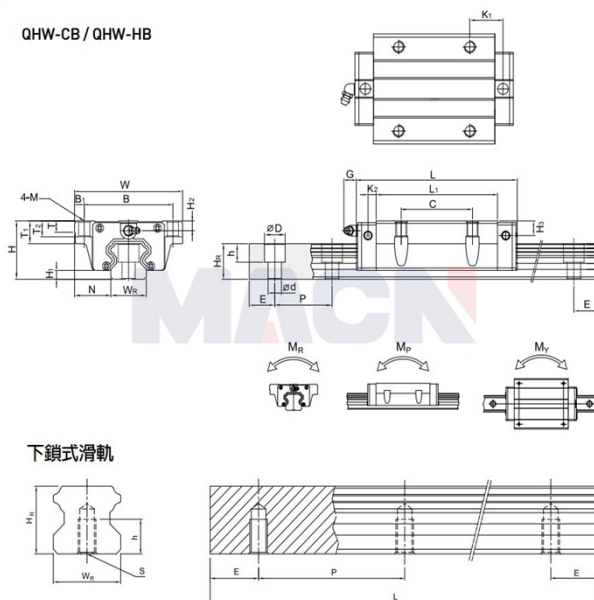

## Model: QHW35HB

### Param

Guide rail model:	QHW35HB
Slider special processing:	无
Number type of slider:	单个
Guide rail fixation mode:	上锁式
Guide rail length L:	440
L computational formula:	$L=(n-1) \times P+2 \times E$ n=1,2,3....
Special processing of guide rail:	无
Pre-pressure grade:	无预压(ZO)
accuracy class:	普通(C)
dustproof equipped with grade:	标准防尘配备
Dust equipped with:	标准(刮油片+防尘片)
Special selection:	无
RC reinforced bolt cover:	无
Component size:	
H:	48
H1:	7.5
N:	33
Slider size:	
W:	100
B:	82
B1:	9
C:	62
L:	139.4
L1:	105.8

K1:	25.9
K2:	7.5
G:	12
M:	Φ9
T:	10.1
T1:	18
T2:	13
H2:	8.5
H3:	6.5
Guide track size:	
WR:	34
HR:	29
D:	14
h:	12
d:	9
P:	80
Standard end distance E:	20
Actual end distance:	20
Number of bolt holes n:	6
Guide rail fixed bolt:	M8x25
Rated dynamic load C:	73.59
Rated static load Co:	86.24
Rated static moment MR:	1.45
Rated static moment, MP:	1.33
Rated static moment, MY:	1.33
Slider weight:	2.06
Guide rail weight:	6.30