

QHW-CA / QHW-HA

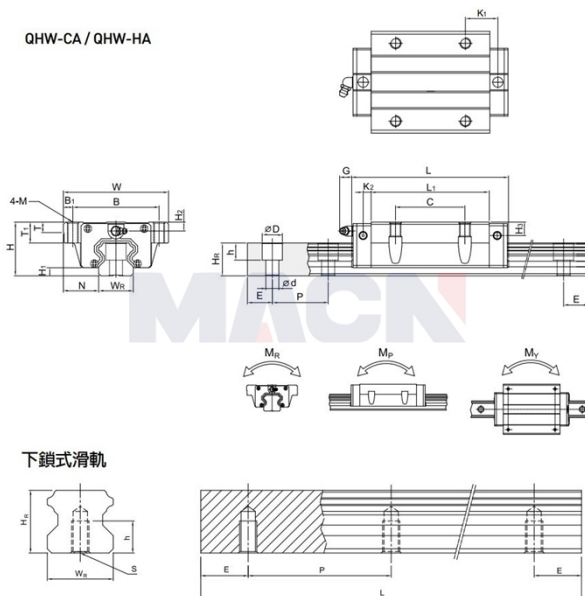

Model: QHW20CA

Param

Guide rail model:	QHW20CA
Slider special processing:	无
Number type of slider:	单个
Guide rail fixation mode:	上锁式
Guide rail length L:	340
L computational formula:	$L=(n-1) \times P+2 \times E$ n=1,2,3....
Special processing of guide rail:	无
Pre-pressure grade:	无预压(ZO)
accuracy class:	普通(C)
dustproof equipped with grade:	标准防尘配备
Dust equipped with:	标准(刮油片+防尘片)
Special selection:	无
RC reinforced bolt cover:	无
Component size:	
H:	30
H1:	4.6
N:	21.5
Slider size:	
W:	63
B:	53
B1:	5
C:	40
L:	76.7
L1:	50.5

K1:	9.75
K2:	6
G:	12
M:	M6
T:	8
T1:	10
H2:	6
H3:	6
Guide track size:	
WR:	20
HR:	17.5
D:	9.5
h:	8.5
d:	6
P:	60
Standard end distance E:	20
Actual end distance:	20
Number of bolt holes n:	6
Guide rail fixed bolt:	M5x16
Rated dynamic load C:	23.08
Rated static load Co:	25.63
Rated static moment MR:	0.26
Rated static moment, MP:	0.19
Rated static moment, MY:	0.19
Slider weight:	0.40
Guide rail weight:	2.21