

QHW-CA / QHW-HA

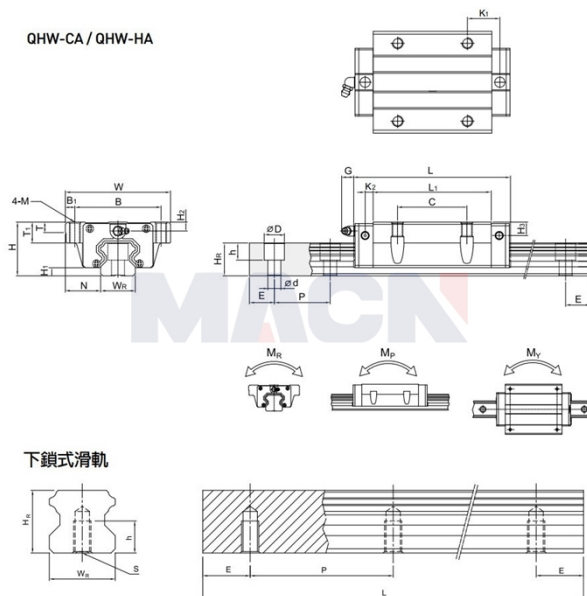

下鎖式滑軌

## Model: QHW25CA

### Param

Guide rail model:	QHW25CA
Slider special processing:	无
Number type of slider:	单个
Guide rail fixation mode:	上锁式
Guide rail length L:	340
L computational formula:	$L=(n-1) \times P+2 \times E$ n=1,2,3....
Special processing of guide rail:	无
Pre-pressure grade:	无预压(ZO)
accuracy class:	普通(C)
dustproof equipped with grade:	标准防尘配备
Dust equipped with:	标准(刮油片+防尘片)
Special selection:	无
RC reinforced bolt cover:	无
Component size:	
H:	36
H1:	5.5
N:	23.5
Slider size:	
W:	70
B:	57
B1:	6.5
C:	45
L:	83.4
L1:	58

K1:	10.7
K2:	6
G:	12
M:	M8
T:	8
T1:	14
H2:	6
H3:	5
Guide track size:	
WR:	23
HR:	22
D:	11
h:	9
d:	7
P:	60
Standard end distance E:	20
Actual end distance:	20
Number of bolt holes n:	6
Guide rail fixed bolt:	M6x20
Rated dynamic load C:	31.78
Rated static load Co:	33.68
Rated static moment MR:	0.39
Rated static moment, MP:	0.31
Rated static moment, MY:	0.31
Slider weight:	0.59
Guide rail weight:	3.21