

QHW-CA / QHW-HA

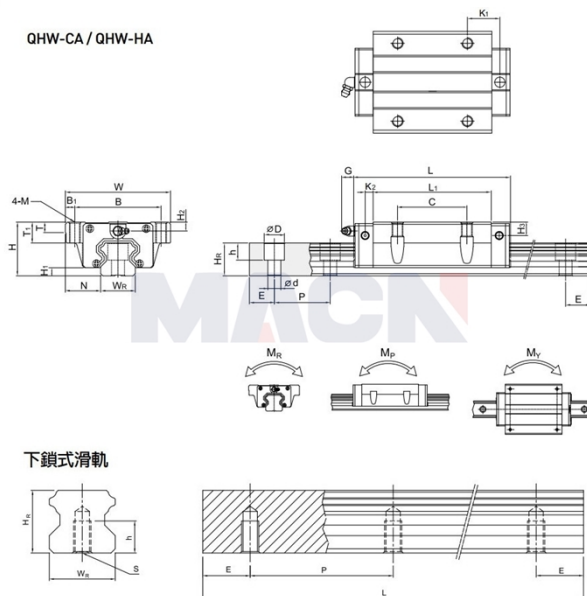

下鎖式滑軌

## Model: QHW30CA

### Param

|                                   |  |
|-----------------------------------|--|
| Guide rail model:                 | QHW30CA                                      |
| Slider special processing:        | 无  |
| Number type of slider:            | 单个   |
| Guide rail fixation mode:         | 上锁式  |
| Guide rail length L:              | 440  |
| L computational formula:          | $L=(n-1) \times P+2 \times E$<br>n=1,2,3.... |
| Special processing of guide rail: | 无  |
| Pre-pressure grade:               | 无预压(ZO)                                      |
| accuracy class:                   | 普通(C)  |
| dustproof equipped with grade:    | 标准防尘配备                                       |
| Dust equipped with:               | 标准(刮油片+防尘片)                                  |
| Special selection:                | 无  |
| RC reinforced bolt cover:         | 无  |
| Component size:                   |  |
| H:                                | 42   |
| H1:                               | 6  |
| N:                                | 31   |
| Slider size:                      |  |
| W:                                | 90   |
| B:                                | 72   |
| B1:                               | 9  |
| C:                                | 52   |
| L:                                | 97.4   |
| L1:                               | 70   |

|                             |       |
|-----------------------------|-------|
| K1:                         | 13.5  |
| K2:                         | 6     |
| G:                          | 12    |
| M:                          | M10   |
| T:                          | 8.5   |
| T1:                         | 16    |
| H2:                         | 6.5   |
| H3:                         | 6     |
| Guide track<br>size:        |       |
| WR:                         | 28    |
| HR:                         | 26    |
| D:                          | 14    |
| h:                          | 12    |
| d:                          | 9     |
| P:                          | 80    |
| Standard end<br>distance E: | 20    |
| Actual end<br>distance:     | 20    |
| Number of bolt<br>holes n:  | 6     |
| Guide rail fixed<br>bolt:   | M8x25 |
| Rated dynamic<br>load C:    | 46.49 |
| Rated static<br>load Co:    | 48.17 |
| Rated static<br>moment MR:  | 0.60  |
| Rated static<br>moment, MP: | 0.50  |
| Rated static<br>moment, MY: | 0.50  |
| Slider weight:              | 1.09  |
| Guide rail<br>weight:       | 4.47  |