

QEW-CA / QEW-SA

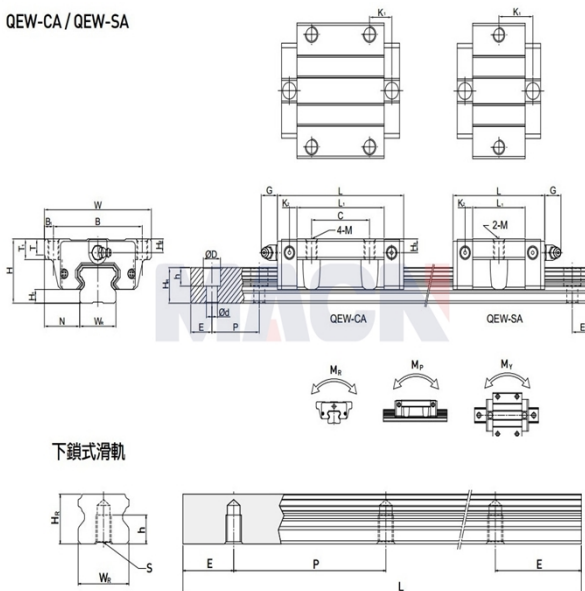

Model: QEW25CA

Param

Guide rail model:	QEW25CA
Slider special processing:	无
Number type of slider:	单个
Guide rail fixation mode:	上锁式
Guide rail length L:	340
L computational formula:	$L=(n-1) \times P+2 \times E$ n=1,2,3....
Special processing of guide rail:	无
Pre-pressure grade:	无预压(ZO)
accuracy class:	普通(C)
dustproof equipped with grade:	标准防尘配备
Dust equipped with:	标准(刮油片+防尘片)
RC reinforced bolt cover:	无
Component size:	
H:	33
H1:	6.2
N:	25
Slider size:	
W:	73
B:	60
B1:	6.5
C:	35
L:	82.6
L1:	59
K1:	16.15

K2:	5
G:	12
M:	M8
T:	7.5
T1:	10
H2:	8
H3:	8
Guide track size:	
WR:	23
HR:	18
D:	11
h:	9
d:	7
P:	60
Standard end distance E:	20
Actual end distance:	20
Number of bolt holes n:	6
Guide rail fixed bolt:	M6x20
Rated dynamic load C:	26.03
Rated static load Co:	31.49
Rated static moment MR:	0.37
Rated static moment, MP:	0.29
Rated static moment, MY:	0.29
Slider weight:	0.58
Guide rail weight:	2.67