

QEH-CA / QEH-SA

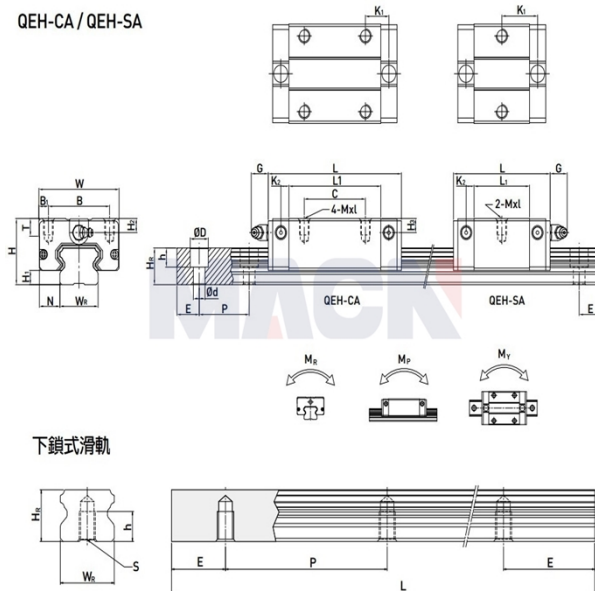

Model: QEH30CA

Param

Guide rail model:	QEH30CA
Slider special processing:	无
Number type of slider:	单个
Guide rail fixation mode:	上锁式
Guide rail length L:	440
L computational formula:	$L=(n-1) \times P+2 \times E$ n=1,2,3....
Special processing of guide rail:	无
Pre-pressure grade:	无预压(ZO)
accuracy class:	普通(C)
dustproof equipped with grade:	标准防尘配备
Dust equipped with:	标准(刮油片+防尘片)
RC reinforced bolt cover:	无
Component size:	
H:	42
H1:	10
N:	16
Slider size:	
W:	60
B:	40
B1:	10
C:	40
L:	98.1
L1:	70.1
K1:	20.05

K2:	6
G:	12
MxL:	M8x12
T:	9
H2:	8
H3:	9
Guide track size:	
WR:	28
HR:	23
D:	11
h:	12
d:	9
P:	80
Standard end distance E:	20
Actual end distance:	20
Number of bolt holes n:	6
Guide rail fixed bolt:	M6x25
Rated dynamic load C:	37.92
Rated static load Co:	46.63
Rated static moment MR:	0.67
Rated static moment, MP:	0.51
Rated static moment, MY:	0.51
Slider weight:	0.75
Guide rail weight:	4.35