

QEH-CA / QEH-SA

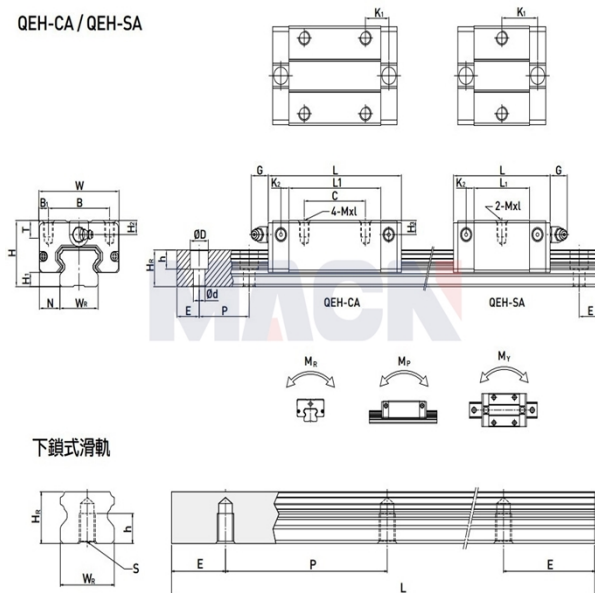

下鎖式滑軌

Model: QEH35CA

Param

Guide rail model:	QEH35CA
Slider special processing:	无
Number type of slider:	单个
Guide rail fixation mode:	上锁式
Guide rail length L:	440
L computational formula:	$L=(n-1) \times P+2 \times E$ n=1,2,3....
Special processing of guide rail:	无
Pre-pressure grade:	无预压(ZO)
accuracy class:	普通(C)
dustproof equipped with grade:	标准防尘配备
Dust equipped with:	标准(刮油片+防尘片)
RC reinforced bolt cover:	无
Component size:	
H:	48
H1:	11
N:	18
Slider size:	
W:	70
B:	50
B1:	10
C:	50
L:	108
L1:	83
K1:	21.3

K2:	6.25
G:	12
MxL:	M8x12
T:	10
H2:	8.5
H3:	8.5
Guide track size:	
WR:	34
HR:	27.5
D:	14
h:	12
d:	9
P:	80
Standard end distance E:	20
Actual end distance:	20
Number of bolt holes n:	6
Guide rail fixed bolt:	M8x25
Rated dynamic load C:	51.18
Rated static load Co:	59.28
Rated static moment MR:	1.00
Rated static moment, MP:	0.75
Rated static moment, MY:	0.75
Slider weight:	1.19
Guide rail weight:	6.14