

QWW-CC

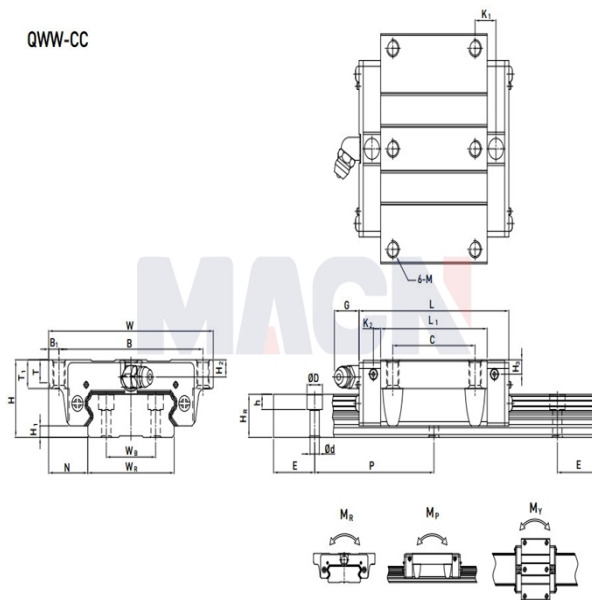

## Model: QWW35CC

### Param

Guide rail model:	QWW35CC
Slider special processing:	无
Number type of slider:	单个
Guide rail length L:	440
L computational formula:	$L=(n-1) \times P+2 \times E$ n=1,2,3....
Special processing of guide rail:	无
Pre-pressure grade:	无预压(ZO)
accuracy class:	普通(C)
dustproof equipped with grade:	标准防尘配备
Dust equipped with:	标准(刮油片+防尘片)
RC reinforced bolt cover:	无
Component size:	
H:	35
H1:	4
N:	25.5
Slider size:	
W:	120
B:	107
B1:	6.5
C:	60
L1:	83
L:	107
K1:	21.5
K2:	5.5
G:	12

M:	M8
T:	11.2
T1:	14
H2:	8
H3:	6.5
Guide track size:	
WR:	69
WB:	40
HR:	19
D:	11
h:	9
d:	7
P:	80
Standard end distance E:	20
Actual end distance:	20
Number of bolt holes n:	6
Guide rail fixed bolt:	M6x20
Rated dynamic load C:	36.80
Rated static load Co:	49.20
Rated static moment MR:	1.51
Rated static moment, MP:	0.65
Rated static moment, MY:	0.65
Slider weight:	1.26
Guide rail weight:	9.70