

RGW-CC / RGW-HC

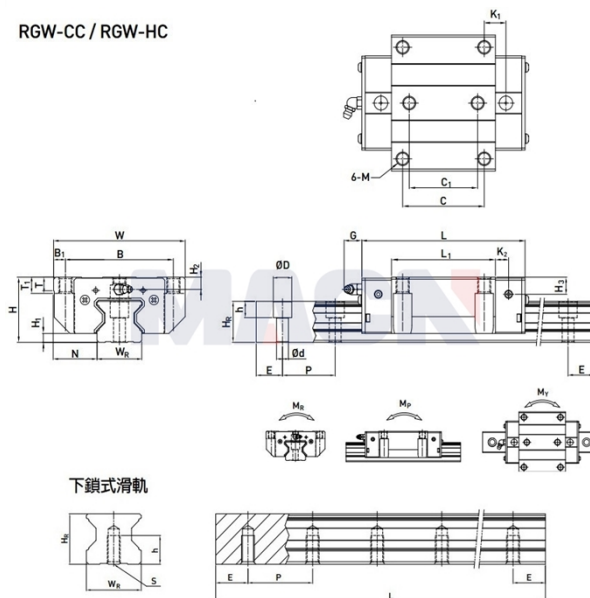

下鎖式滑軌

## Model: RGW25HC

### Param

Guide rail model:	RGW25HC
Slider special processing:	无
Number type of slider:	单个
Guide rail fixation mode:	上锁式
Guide rail length L:	340
L computational formula:	$L=(n-1) \times P+2 \times E$ n=1,2,3....
Special processing of guide rail:	无
Pre-pressure grade:	无预压(ZO)
accuracy class:	高(H)
dustproof equipped with grade:	标准防尘配备
Dust equipped with:	标准(刮油片+防尘片)
Special selection:	无
RC reinforced bolt cover:	无
Component size:	
H:	36
H1:	5.5
N:	23.5
Slider size:	
W:	70
B:	57
B1:	6.5
C:	45
C1:	40
L:	114.4

L1:	81
K1:	24
K2:	7.25
G:	12
M:	M8
T:	9.5
T1:	10
H2:	6.2
H3:	6
Guide track size:	
WR:	23
HR:	23.6
D:	11
h:	9
d:	7
P:	30
Standard end distance E:	20
Actual end distance:	20
Number of bolt holes n:	11
Guide rail fixed bolt:	M6x20
Rated dynamic load C:	33.90
Rated static load Co:	73.40
Rated static moment MR:	0.975
Rated static moment, MP:	0.991
Rated static moment, MY:	0.991
Slider weight:	0.91
Guide rail weight:	3.08