

RGW-CC / RGW-HC

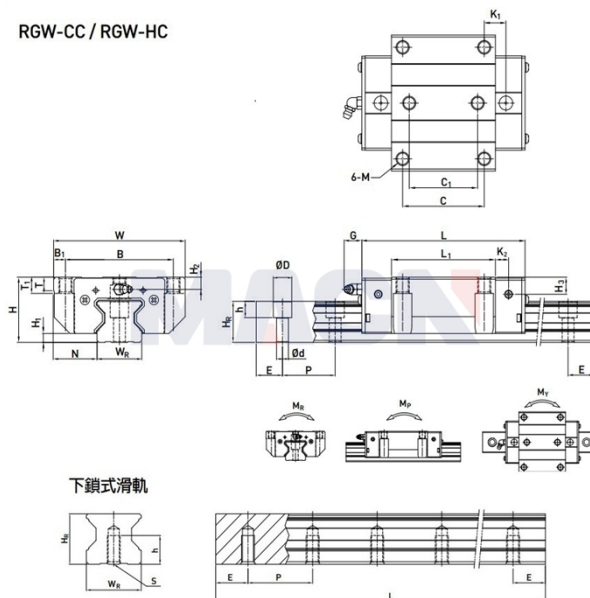

Model: RGW35HC

Param

Guide rail model:	RGW35HC
Slider special processing:	无
Number type of slider:	单个
Guide rail fixation mode:	上锁式
Guide rail length L:	440
L computational formula:	$L=(n-1) \times P+2 \times E$ $n=1,2,3, \dots$
Special processing of guide rail:	无
Pre-pressure grade:	无预压(ZO)
accuracy class:	高(H)
dustproof equipped with grade:	标准防尘配备
Dust equipped with:	标准(刮油片+防尘片)
Special selection:	无
RC reinforced bolt cover:	无
Component size:	
H:	48
H1:	6.5
N:	33
Slider size:	
W:	100
B:	82
B1:	9
C:	62
C1:	52
L:	151.5

L1:	106.5
K1:	30.25
K2:	10
G:	12
M:	M10
T:	12
T1:	13
H2:	9
H3:	12.6
Guide track size:	
WR:	34
HR:	30.2
D:	14
h:	12
d:	9
P:	40
Standard end distance E:	20
Actual end distance:	20
Number of bolt holes n:	11
Guide rail fixed bolt:	M8x25
Rated dynamic load C:	73.10
Rated static load Co:	142.00
Rated static moment MR:	2.93
Rated static moment, MP:	2.60
Rated static moment, MY:	2.60
Slider weight:	2.40
Guide rail weight:	6.06