

RGW-CC / RGW-HC

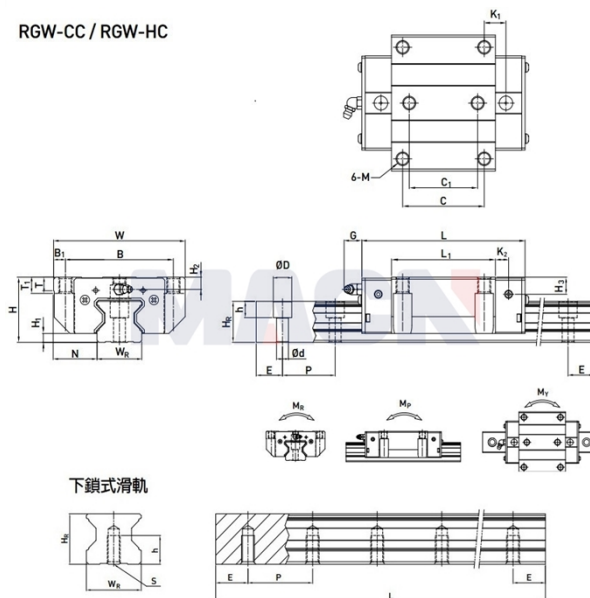

Model: RGW55HC

Param

Guide rail model:	RGW55HC
Slider special processing:	无
Number type of slider:	单个
Guide rail fixation mode:	上锁式
Guide rail length L:	900
L computational formula:	$L=(n-1) \times P+2 \times E$ $n=1,2,3, \dots$
Special processing of guide rail:	无
Pre-pressure grade:	无预压(ZO)
accuracy class:	高(H)
dustproof equipped with grade:	标准防尘配备
Dust equipped with:	标准(刮油片+防尘片)
Special selection:	无
RC reinforced bolt cover:	无
Component size:	
H:	70
H1:	10
N:	43.5
Slider size:	
W:	140
B:	116
B1:	12
C:	95
C1:	70
L:	232

L1:	173.8
K1:	51.9
K2:	12.5
G:	12.9
M:	M14
T:	16
T1:	17
H2:	12
H3:	17.5
Guide track size:	
WR:	53
HR:	44
D:	23
h:	20
d:	16
P:	60
Standard end distance E:	30
Actual end distance:	30
Number of bolt holes n:	15
Guide rail fixed bolt:	M14x45
Rated dynamic load C:	167.80
Rated static load Co:	348.00
Rated static moment MR:	11.15
Rated static moment, MP:	10.25
Rated static moment, MY:	10.25
Slider weight:	7.61
Guide rail weight:	13.98