

RGW-CC / RGW-HC

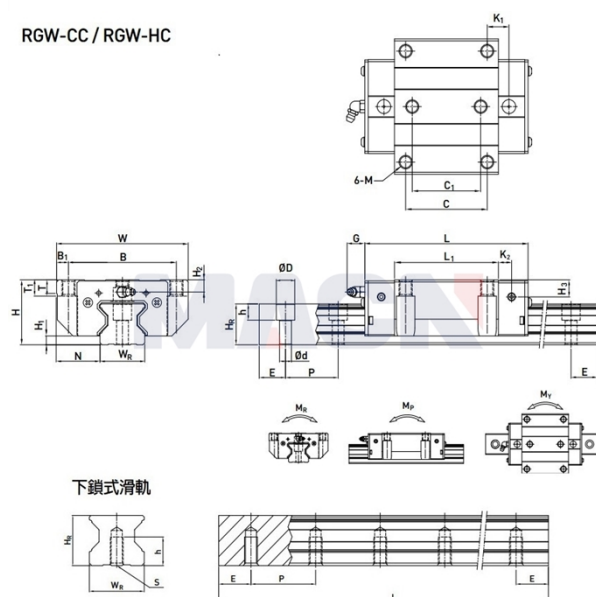

Model: RGW30CC

Param

Guide rail model:	RGW30CC
Slider special processing:	无
Number type of slider:	单个
Guide rail fixation mode:	上锁式
Guide rail length L:	440
L computational formula:	$L=(n-1) \times P+2 \times E$ n=1,2,3....
Special processing of guide rail:	无
Pre-pressure grade:	无预压(ZO)
accuracy class:	高(H)
dustproof equipped with grade:	标准防尘配备
Dust equipped with:	标准(刮油片+防尘片)
Special selection:	无
RC reinforced bolt cover:	无
Component size:	
H:	42
H1:	6
N:	31
Slider size:	
W:	90
B:	72
B1:	9
C:	52
C1:	44
L:	109.8

L1:	71
K1:	17.5
K2:	8
G:	12
M:	M10
T:	9.5
T1:	10
H2:	6.5
H3:	7.3
Guide track size:	
WR:	28
HR:	28
D:	14
h:	12
d:	9
P:	40
Standard end distance E:	20
Actual end distance:	20
Number of bolt holes n:	11
Guide rail fixed bolt:	M8x25
Rated dynamic load C:	39.10
Rated static load Co:	82.10
Rated static moment MR:	1.445
Rated static moment, MP:	1.060
Rated static moment, MY:	1.060
Slider weight:	1.16
Guide rail weight:	4.41