

RGW-CC / RGW-HC

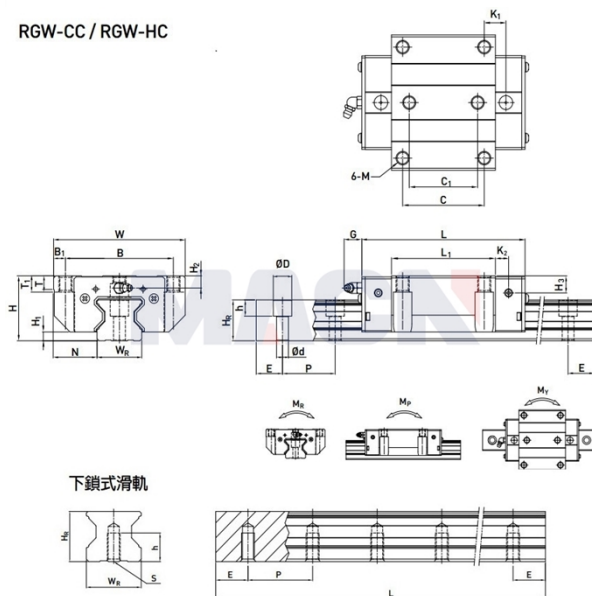

## Model: RGW65CC

### Param

Guide rail model:	RGW65CC
Slider special processing:	无
Number type of slider:	单个
Guide rail fixation mode:	上锁式
Guide rail length L:	1270
L computational formula:	$L=(n-1) \times P+2 \times E$ n=1,2,3....
Special processing of guide rail:	无
Pre-pressure grade:	无预压(ZO)
accuracy class:	高(H)
dustproof equipped with grade:	标准防尘配备
Dust equipped with:	标准(刮油片+防尘片)
Special selection:	无
RC reinforced bolt cover:	无
Component size:	
H:	90
H1:	12
N:	53.5
Slider size:	
W:	170
B:	142
B1:	14
C:	110
C1:	82
L:	232

L1:	160
K1:	40.8
K2:	15.8
G:	12.9
M:	M16
T:	22
T1:	23
H2:	15
H3:	15
Guide track size:	
WR:	63
HR:	53
D:	26
h:	22
d:	18
P:	75
Standard end distance E:	35
Actual end distance:	35
Number of bolt holes n:	17
Guide rail fixed bolt:	M16x50
Rated dynamic load C:	213.00
Rated static load Co:	411.60
Rated static moment MR:	16.20
Rated static moment, MP:	11.59
Rated static moment, MY:	11.59
Slider weight:	11.63
Guide rail weight:	20.22