

RGH-CA / RGH-HA

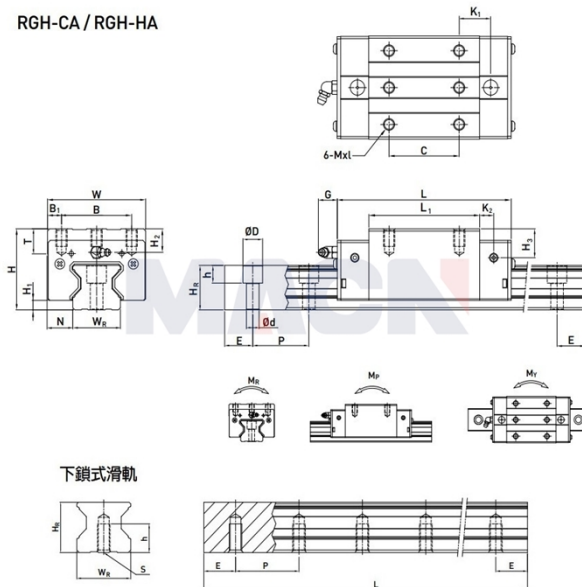

Model: RGH15CA

Param

Guide rail model:	RGH15CA
Slider special processing:	无
Number type of slider:	单个
Guide rail fixation mode:	上锁式
Guide rail length L:	340
L computational formula:	$L=(n-1) \times P+2 \times E$ $n=1,2,3, \dots$
Special processing of guide rail:	无
Pre-pressure grade:	无预压(ZO)
accuracy class:	高(H)
dustproof equipped with grade:	标准防尘配备
Dust equipped with:	标准(刮油片+防尘片)
Special selection:	无
RC reinforced bolt cover:	无
Component size:	
H:	28
H1:	4
N:	9.5
Slider size:	
W:	34
B:	26
B1:	4
C:	26
L:	68
L1:	45

K1:	13.4
K2:	4.7
G:	5.3
MxL:	M4x8
T:	6
H2:	7.6
H3:	10.1
Guide track size:	
WR:	15
HR:	16.5
D:	7.5
h:	5.7
d:	4.5
P:	30
Standard end distance E:	20
Actual end distance:	20
Number of bolt holes n:	11
Guide rail fixed bolt:	M4x16
Rated dynamic load C:	11.30
Rated static load Co:	24.00
Rated static moment MR:	0.311
Rated static moment, MP:	0.173
Rated static moment, MY:	0.173
Slider weight:	0.20
Guide rail weight:	1.80