

RGH-CA / RGH-HA

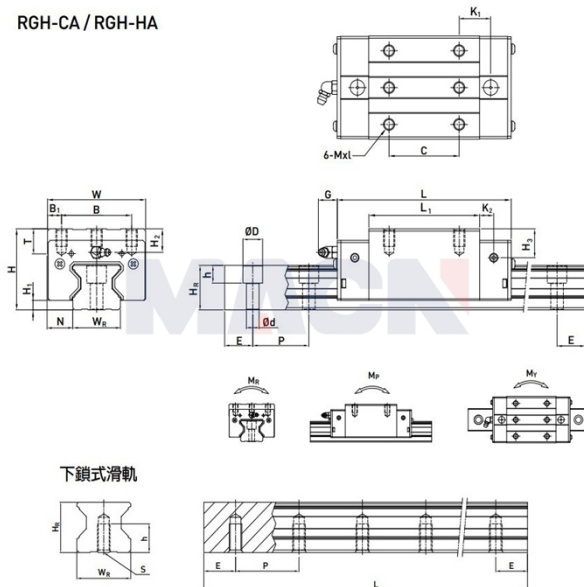

## Model: RGH25CA

### Param

Guide rail model:	RGH25CA
Slider special processing:	无
Number type of slider:	单个
Guide rail fixation mode:	上锁式
Guide rail length L:	340
L computational formula:	$L=(n-1) \times P+2 \times E$ n=1,2,3....
Special processing of guide rail:	无
Pre-pressure grade:	无预压(ZO)
accuracy class:	高(H)
dustproof equipped with grade:	标准防尘配备
Dust equipped with:	标准(刮油片+防尘片)
Special selection:	无
RC reinforced bolt cover:	无
Component size:	
H:	40
H1:	5.5
N:	12.5
Slider size:	
W:	48
B:	35
B1:	6.5
C:	35
L:	97.9
L1:	64.5

K1:	20.75
K2:	7.25
G:	5.3
MxL:	M6x8
T:	9.5
H2:	10.2
H3:	10
Guide track size:	
WR:	23
HR:	23.6
D:	11
h:	9
d:	7
P:	30
Standard end distance E:	20
Actual end distance:	20
Number of bolt holes n:	11
Guide rail fixed bolt:	M6x20
Rated dynamic load C:	27.70
Rated static load Co:	57.10
Rated static moment MR:	0.758
Rated static moment, MP:	0.605
Rated static moment, MY:	0.605
Slider weight:	0.61
Guide rail weight:	3.08