

RGH-CA / RGH-HA

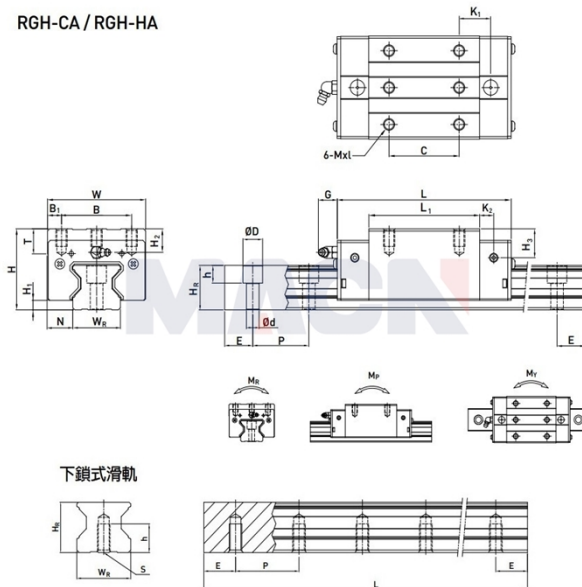

Model: RGH35CA

Param

Guide rail model:	RGH35CA
Slider special processing:	无
Number type of slider:	单个
Guide rail fixation mode:	上锁式
Guide rail length L:	440
L computational formula:	$L=(n-1) \times P+2 \times E$ $n=1,2,3, \dots$
Special processing of guide rail:	无
Pre-pressure grade:	无预压(ZO)
accuracy class:	高(H)
dustproof equipped with grade:	标准防尘配备
Dust equipped with:	标准(刮油片+防尘片)
Special selection:	无
RC reinforced bolt cover:	无
Component size:	
H:	55
H1:	6.5
N:	18
Slider size:	
W:	70
B:	50
B1:	10
C:	50
L:	124
L1:	79

K1:	22.5
K2:	10
G:	12
MxL:	M8x12
T:	12
H2:	16
H3:	19.6
Guide track size:	
WR:	34
HR:	30.2
D:	14
h:	12
d:	9
P:	40
Standard end distance E:	20
Actual end distance:	20
Number of bolt holes n:	11
Guide rail fixed bolt:	M8x25
Rated dynamic load C:	57.90
Rated static load Co:	105.20
Rated static moment MR:	2.17
Rated static moment, MP:	1.44
Rated static moment, MY:	1.44
Slider weight:	1.57
Guide rail weight:	6.06