

QRW-CC / QRW-HC

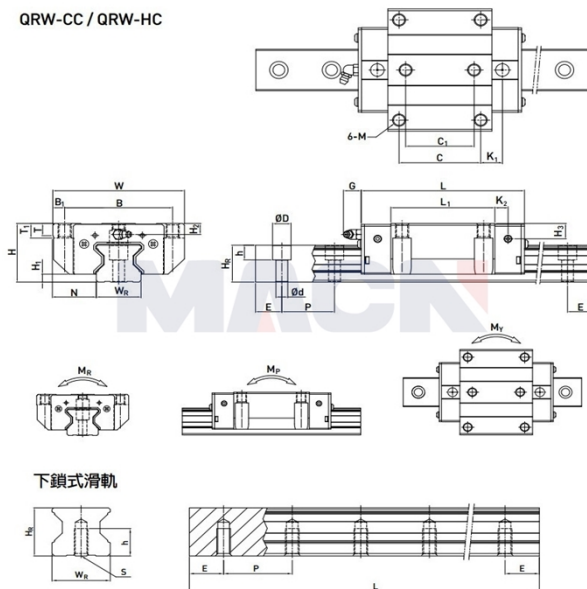

下鎖式滑軌

## Model: QRW45HC

### Param

Guide rail model:	QRW45HC
Slider special processing:	无
Number type of slider:	单个
Guide rail fixation mode:	上锁式
Guide rail length L:	780
L computational formula:	$L=(n-1) \times P+2 \times E$ n=1,2,3....
Special processing of guide rail:	无
Pre-pressure grade:	无预压(ZO)
accuracy class:	高(H)
dustproof equipped with grade:	标准防尘配备
Dust equipped with:	标准(刮油片+防尘片)
Special selection:	无
RC reinforced bolt cover:	无
Component size:	
H:	60
H1:	8
N:	37.5
Slider size:	
W:	120
B:	100
B1:	10
C:	80
C1:	60
L:	187

L1:	139.8
K1:	37.9
K2:	10
G:	12.9
M:	M10
T:	14
T1:	15
H2:	10
H3:	14
Guide track size:	
WR:	45
HR:	38
D:	20
h:	17
d:	14
P:	52.5
Standard end distance E:	22.5
Actual end distance:	22.5
Number of bolt holes n:	15
Guide rail fixed bolt:	M12x35
Rated dynamic load C:	116
Rated static load Co:	230.9
Rated static moment MR:	6.33
Rated static moment, MP:	5.47
Rated static moment, MY:	5.47
Slider weight:	4.54
Guide rail weight:	9.97