

Model: UCFL210-30

Shaft Dia.

d (in.): 17/8

d (mm):

Dimensions(mm)(inch)

H: 7.7559

J: 6.1881

L: 4.5276

A2: 0.8661

A1: 0.6299

A: 1.5748

N: 0.7480

E: 2.1496

S: 0.7480

Unit No.

Unit No.: UCFL210-30

Bolt Used (mm) (in.)

Bolt Used (mm) (in.): 5/8

Bearing No.

Bearing No.: UC210-30

Housing No.

Housing No.:

Weight(kg)(lb)

Weight(kg)(lb): 4.7

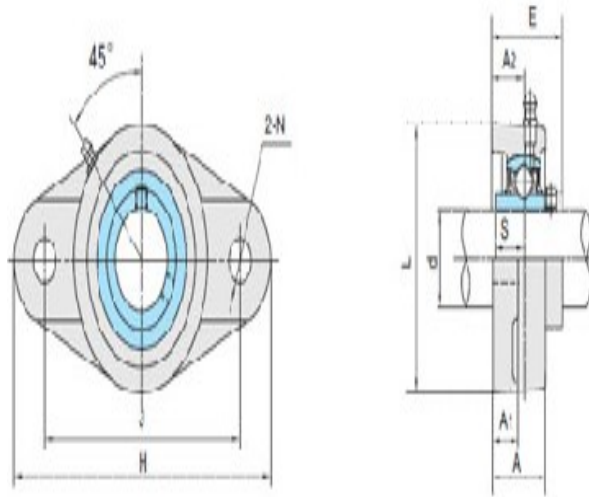

UCFL2