

**Model: UCFL309**

Shaft Dia.

d (in.):	
d (mm):	45

Dimensions(mm)(inch)

H:	230
J:	177
L:	125
A2:	25
A1:	18
A:	44
N:	25
E:	60
S:	22

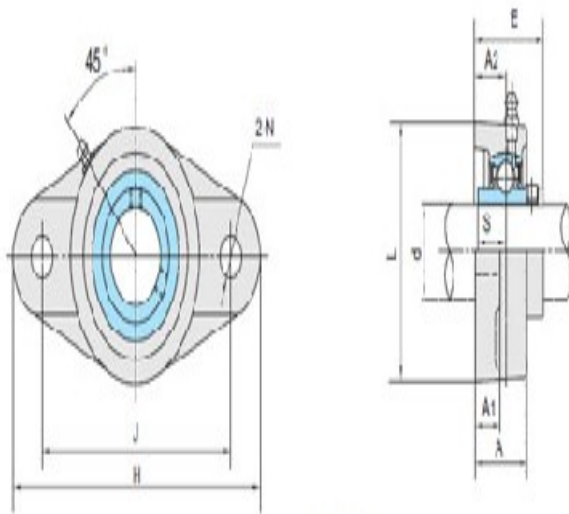
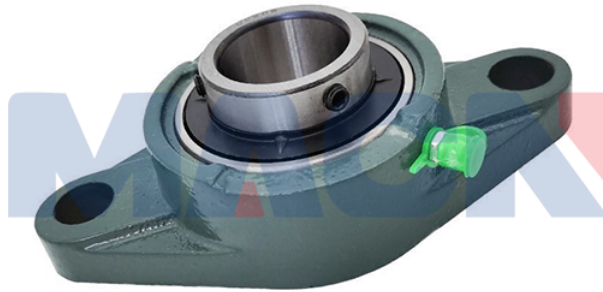

UCFL3

Unit No.

Unit No.:	UCFL309
-----------	---------

Bolt Used (mm) (in.)

Bolt Used (mm) (in.):	M22
-----------------------	-----

Bearing No.

Bearing No.:	UC309
--------------	-------

Housing No.

Housing No.:	FL309
--------------	-------

Weight(kg)(lb)

Weight(kg)(lb):	3.53
-----------------	------