

Model: UKFL215+H2315

Shaft Dia.

d (in.):	
d (mm):	65

Dimensions(mm)(inch)

H:	275
J:	225
L:	165
A2:	34
A1:	22
A:	56
N:	23
E:	69.5
S1:	35.5

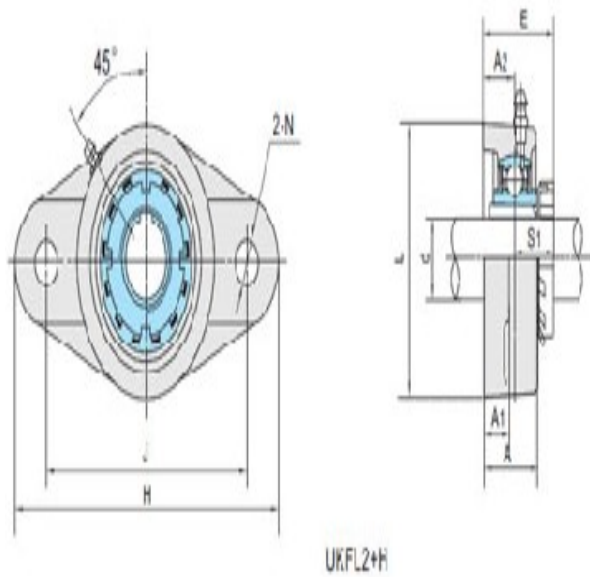
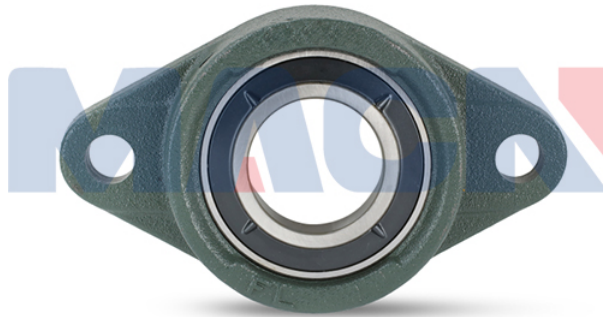

Unit No.

Unit No.:	UKFL215+H2315
	5

Bolt Used (mm) (in.)

Bolt Used (mm)	M20
(in.):	

Bearing No.

Bearing No.:	UK215
--------------	-------

Housing No.

Housing No.:	FL215
--------------	-------

Adapter Used.

Adapter Used.:	H2315
----------------	-------

Weight(kg)(lb)

Weight(kg)(lb):	6.59
-----------------	------