

Model: UKFL211+H2311

Shaft Dia.

d (in.):	
d (mm):	50

Dimensions(mm)(inch)

H:	224
J:	184
L:	130
A2:	25
A1:	18
A:	43
N:	19
E:	53.5
S1:	28.5

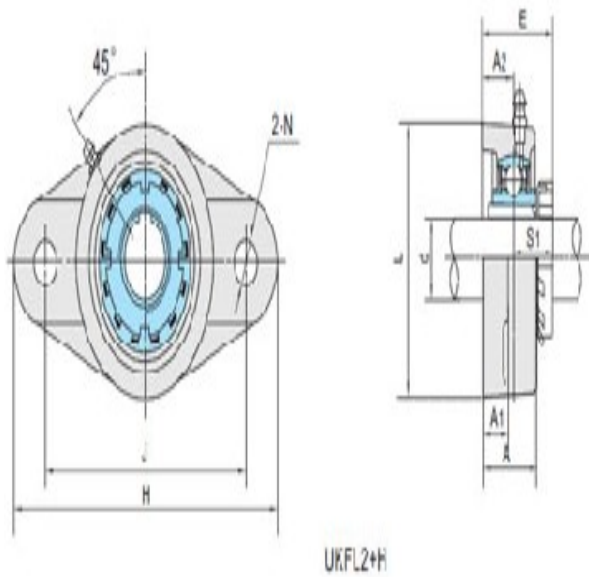
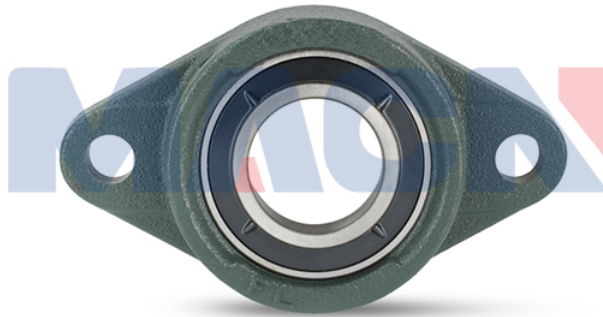

Unit No.

Unit No.:	UKFL211+H2311
	1

Bolt Used (mm) (in.)

Bolt Used (mm)	M16
(in.):	

Bearing No.

Bearing No.:	UK211
--------------	-------

Housing No.

Housing No.:	FL211
--------------	-------

Adapter Used.

Adapter Used.:	H2311
----------------	-------

Weight(kg)(lb)

Weight(kg)(lb):	3.23
-----------------	------