

**Model: UKFL210+H2310**

Shaft Dia.

d (in.):	
d (mm):	45

Dimensions(mm)(inch)

H:	197
J:	157
L:	115
A2:	22
A1:	16
A:	40
N:	19
E:	49.5
S1:	27.5

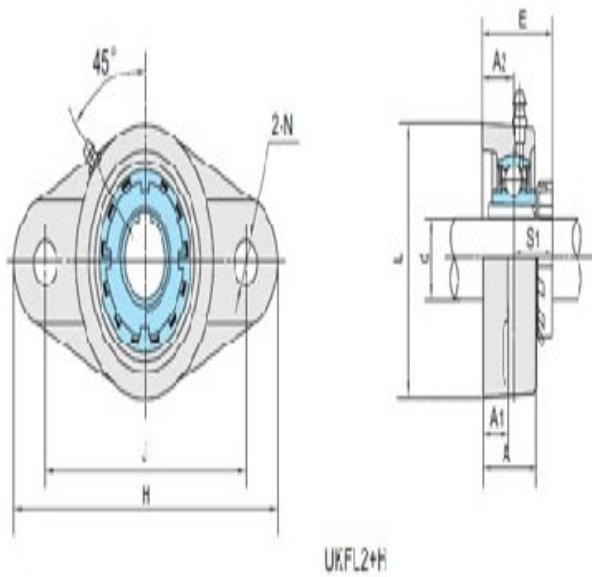
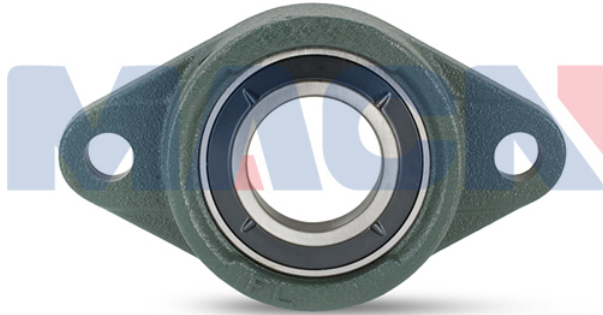

Unit No.

Unit No.:	UKFL210+H2310
	0

Bolt Used (mm) (in.)

Bolt Used (mm)	M16
(in.):	

Bearing No.

Bearing No.:	UK210
--------------	-------

Housing No.

Housing No.:	FL210
--------------	-------

Adapter Used.

Adapter Used.:	H2310
----------------	-------

Weight(kg)(lb)

Weight(kg)(lb):	2.27
-----------------	------