

Model: UKFL209+HS2309

Shaft Dia.

d (in.):	15/8
d (mm):	

Dimensions(mm)(inch)

H:	7.4016
J:	5.8268
L:	4.2520
A2:	0.8661
A1:	0.6299
A:	1.4961
N:	0.7480
E:	1.8898
S1:	1.0236

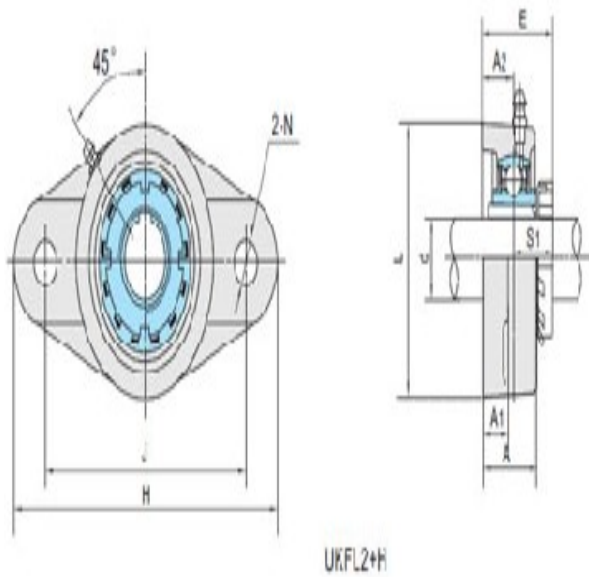
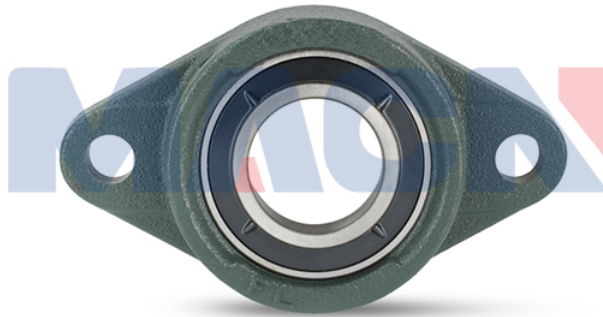

Unit No.

Unit No.:	UKFL209+HS2309
-----------	----------------

Bolt Used (mm) (in.)

Bolt Used (mm)	5/8
(in.):	

Bearing No.

Bearing No.:

Housing No.

Housing No.:

Adapter Used.

Adapter Used.: HS2309

Weight(kg)(lb)

Weight(kg)(lb):