

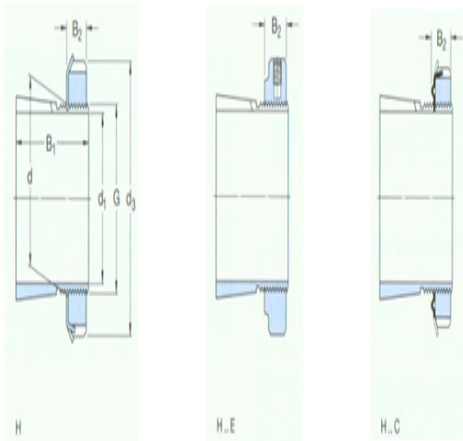

型号: H305C

尺寸

d ₁ :	20
d:	25
d ₃ :	38
B ₁ :	29
B ₂ :	8.5
G:	M25×1.5
质量:	0.071



型号

带锁紧螺母和锁定装置的紧定套:	H305C
锁紧螺母:	KM5
锁紧装置:	MB5C
适用的液压螺母:	-