

QEW-CA / QEW-SA

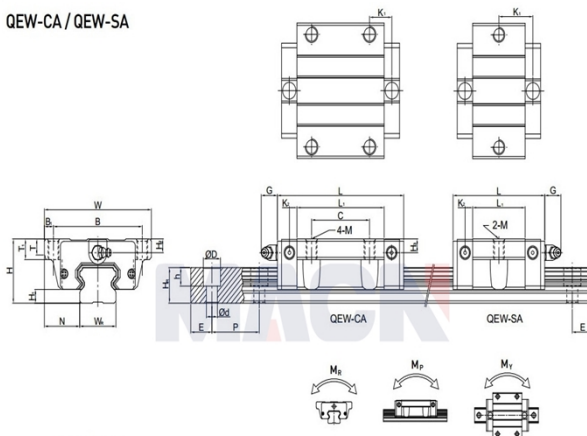

下锁式滑轨

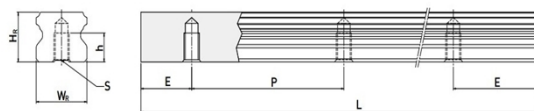

## 型号: QEW30CA

### 参数

导轨型号:	QEW30CA
滑块特殊加工:	无
滑块数量类型:	单个
导轨固定方式:	上锁式
导轨长度L:	440
L计算公式:	$L=(n-1) \times P+2 \times E$ n=1,2,3....
导轨特殊加工:	无
预压等级:	无预压(ZO)
精度等级:	普通(C)
防尘配备等级:	标准防尘配备
防尘配备:	标准(刮油片+防尘片)
RC强化型螺栓盖:	无
组件尺寸:	
H:	42
H1:	10
N:	31
滑块尺寸:	
W:	90
B:	72
B1:	9
C:	40
L:	98.1
L1:	70.1
K1:	20.05
K2:	6
G:	12
M:	M10
T:	7
T1:	10
H2:	8
H3:	9
导轨尺寸:	
WR:	28

HR:	23
D:	11
h:	12
d:	9
P:	80
标准端距E:	20
实际端距:	20
螺栓孔数n:	6
导轨固定螺栓:	M6x25
额定动载荷C:	37.92
额定静载荷Co:	46.63
额定静力矩MR:	0.67
额定静力矩MP:	0.51
额定静力矩MY:	0.51
滑块重量:	1.03
导轨重量:	4.35